

Positioning Module Software Package

Operating Manual

mitsubishi



Mitsubishi Programmable
Logic Controller

MELSEC-Q

SW0D5C-QD75P-E

• SAFETY INSTRUCTIONS •

(Always read these instructions before using this equipment.)

Before using this product, please read this manual and the relevant manuals introduced in this manual carefully and pay full attention to safety to handle the product correctly.

The instructions given in this manual are concerned with this product. For the safety instructions of the programmable controller system, please read the CPU module user's manual.

In this manual, the safety instructions are ranked as "WARNING" and "CAUTION".



DANGER

Indicates that incorrect handling may cause hazardous conditions, resulting in death or severe injury.



CAUTION

Indicates that incorrect handling may cause hazardous conditions, resulting in medium or slight personal injury or physical damage.

Note that the  CAUTION level may lead to a serious consequence according to the circumstances. Always follow the instructions of both levels because they are important to personal safety.

Please save this manual to make it accessible when required and always forward it to the end user.

[Start-Up/Maintenance Instructions]

CAUTION

- Before performing the OPR, JOG operation, inching operation, positioning data test or other operation in the test mode, read the manual carefully, fully ensure safety, and set the PLC CPU to STOP.
Not doing so can damage the machine or cause an accident due to misoperation.

REVISIONS

* The manual number is given on the bottom left of the back cover.

Print Date	* Manual Number	Revision
Feb., 2000	SH (NA)-080057-A	First edition
May., 2000	SH (NA)-080057-B	Correction Section 4.1, 7.4, Chapter 9, Section 11.1.4, Section 11.5
Oct., 2000	SH (NA)-080057-C	Correction CONTENTS, Chapter 1, Section 2.1, Chapter 6, Section 6.1, Section 7.1, Section 8.2.1, Chapter 9, Section 10.4, APPENDIX, INDEX

Japanese Manual Version SH-080048-D

This manual confers no industrial property rights or any rights of any other kind, nor does it confer any patent licenses. Mitsubishi Electric Corporation cannot be held responsible for any problems involving industrial property rights which may occur as a result of using the contents noted in this manual.

Recommendation of Software Registration

After you have acknowledged the contents of the "Software Usage Agreement" supplied with the product, fill out the "Software Registration Card" and return it to us to obtain the following services.

We will send you the user ID and "Registration Confirmation Card" after making the user registration of the "Software Registration Card" you returned.

(No extra charge is needed for registration.)

(1) Software registration

By returning the "Software Registration Card" supplied with the product, we offer you the new product news, update information and other latest information by direct mail.

(2) Instructions for inquiries

When making inquiries, please give us specific and clear information in the terms used in the manual.

Please give us detailed information on the phenomenon that may have caused the problem as we need the information to reproduce that phenomenon.

Please contact the corresponding makers for the operating system of the personal computer and the commercially available software of other companies.

INTRODUCTION

Thank you for choosing the Mitsubishi MELSEC-Q Series General-Purpose Programmable Logic Controller. Before using the product, please read this manual carefully to use the equipment to its optimum.

SAFETY INSTRUCTIONS.....	A- 1
REVISION	A- 2
Recommendation of Software Registration.....	A- 3
CONTENTS.....	A- 4
About Manuals	A- 7
How to Use This Manual.....	A- 8
About the Generic Terms and Abbreviations	A-10
Packing List	A-10

CONTENTS

1. OVERVIEW	1- 1 to 1- 8
1.1 Features	1- 2
1.2 Manual Makeup.....	1- 6
1.3 Additions/Modifications Function according to SW0D5C-QD75P-E Versions.....	1- 8
2. SYSTEM CONFIGURATION	2- 1 to 2- 6
2.1 System Configuration.....	2- 1
2.2 Operating Environment.....	2- 5
3. FUNCTION LIST	3- 1 to 3- 4
3.1 Function List	3- 1
3.2 Menu list	3- 3
4. INSTALLATION AND UNINSTALLATION	4- 1 to 4-12
4.1 Installation	4- 1
4.2 Uninstallation.....	4- 6
4.3 Starting SW□D5C-QD75P-E	4-10
4.4 Exiting SW□D5C-QD75P-E	4-11
5. SCREEN MAKEUP AND BASIC OPERATIONS	5- 1 to 5- 4
5.1 Screen Makeup and Display Selection	5- 1
5.2 Basic Operations.....	5- 2
6. PROJECT CREATION	6- 1 to 6-14
6.1 Creating a New Project.....	6- 2
6.2 Opening the Existing Project	6- 5

6.3 Saving the Project	6- 6
6.4 Closing the Project	6- 7
6.5 Deleting the Project	6- 8
6.6 Reading Other Format Files	6- 9
6.6.1 Reading SW11VD-AD75P-E format file	6- 9
6.6.2 Reading the CSV format file	6-11
6.7 Write to CSV Format File	6-13

7. SYSTEM CHECKING FROM PERIPHERAL DEVICE	7- 1 to 7- 8
--	---------------------

7.1 Connection Setup	7- 1
7.2 System Monitor	7- 4
7.3 Checking the QD75 Function Version (OS Information)	7- 5
7.4 Checking Connect	7- 6

8. DATA SETTING	8- 1 to 8-16
------------------------	---------------------

8.1 Parameter Setting	8- 1
8.2 Positioning Data Setting	8- 3
8.2.1 Positioning data	8- 3
8.2.2 M code comment	8- 8
8.3 Simulation	8- 9
8.4 Block Start Data Setting	8-12
8.4.1 Block start data	8-12
8.4.2 Condition data	8-14
8.5 Error Check	8-16

9. QD75 DATA WRITE/READ/VERIFY	9- 1 to 9- 4
---------------------------------------	---------------------

9.1 Write to QD75/Read from QD75/Verify QD75 Data	9- 1
9.2 Flash ROM write request	9- 4
9.3 QD75 Initialization	9- 4

10. POSITIONING DEBUGGING	10- 1 to 10-32
----------------------------------	-----------------------

10.1 QD75 Error Check	10- 2
10.2 Monitor	10- 3
10.2.1 Monitoring the positioning data/block start data	10- 3
10.2.2 Operation monitor	10- 4
10.2.3 History monitor	10- 6
10.2.4 Signal monitor	10- 8
10.2.5 Axis operation monitor	10-11
10.3 Sampling Monitor	10-17
10.3.1 Sampling signal monitor	10-17
10.3.2 Sampling buffer monitor	10-19
10.4 Test	10-21
10.4.1 Positioning start test	10-22
10.4.2 Present value change test	10-25

10.4.3 Speed change test	10-26
10.4.4 OPR test	10-28
10.4.5 JOG/MPG operation test.....	10-30

11. USEFUL FUNCTIONS	11- 1 to 11-38
-----------------------------	-----------------------

11.1 Useful Functions for Projects.....	11- 1
11.1.1 Verifying the project data	11- 1
11.1.2 Changing the QD75 model after data setting.....	11- 3
11.1.3 Intelligent function utility	11- 4
11.1.4 Multi-module batch write	11- 6
11.2 Edit Functions for Data Setting.....	11- 8
11.2.1 Cut/copy/paste	11- 8
11.2.2 Jump	11-12
11.2.3 Clearing the rows/columns	11-13
11.2.4 Initializing the data.....	11-14
11.3 Copying the Data	11-15
11.3.1 Copying the data on an axis basis (Axis copy)	11-15
11.3.2 Block start copy	11-16
11.4 Navigation Function	11-17
11.5 Option Setting.....	11-20
11.6 Printing the Project Data	11-22
11.6.1 Printer setting	11-22
11.6.2 Printing.....	11-23
11.7 Positioning Data Setting in Test Mode	11-26
11.7.1 Teaching	11-26
11.7.2 Positioning data test edit.....	11-28
11.8 Wave Trace.....	11-29
11.8.1 Wave trace condition setting.....	11-29
11.8.2 Wave trace execution.....	11-31
11.9 Locus Trace.....	11-33
11.9.1 Locus trace condition setting	11-33
11.9.2 Locus trace execution	11-35
11.10 Help	11-37

APPENDIX	Appendix - 1 to Appendix - 2
-----------------	-------------------------------------

APPENDIX 1 QD75 READ/WRITE REFERENCE PROCESSING TIMES.....	Appendix - 1
--	--------------

INDEX	Index - 1 to Index - 5
--------------	-------------------------------

About Manuals

The following manuals are related to this product.
Refer to the following table and request the required ones.

Related Manuals

Manual Name	Manual Number (Model Code)
Type QD75P1/QD75P2/QD75P4, QD75D1/QD75D2/QD75D4 Positioning Module User's Manual Describes the system configuration, performance specifications, functions, handling, pre-operation procedures and troubleshooting of the QD75P1/QD75P2/QD75P4 and QD75D1/QD75D2/QD75D4. (Option)	SH-080058 (13JR09)

CAUTION

- Please note that we do not guarantee the Microsoft® Windows® Operating System corresponding commercially available software products that we introduce.
- The software copyright of this product belongs to Mitsubishi Electric Corporation.
- No part of the contents of this manual may be reproduced or transmitted in any form or by any means without the permission of our company.
- Some part of the contents of this manual may not follow the revisions of the software and hardware.
- In principle, the software of this product should be purchased per computer as a set or under license.
- This product (including the manual) may only be used under the software using agreement.
- Please note that we are not responsible for any influence resulting from the operation of this product (including the manual).
- The contents of this manual are subject to change without notice.

How to Use This Manual

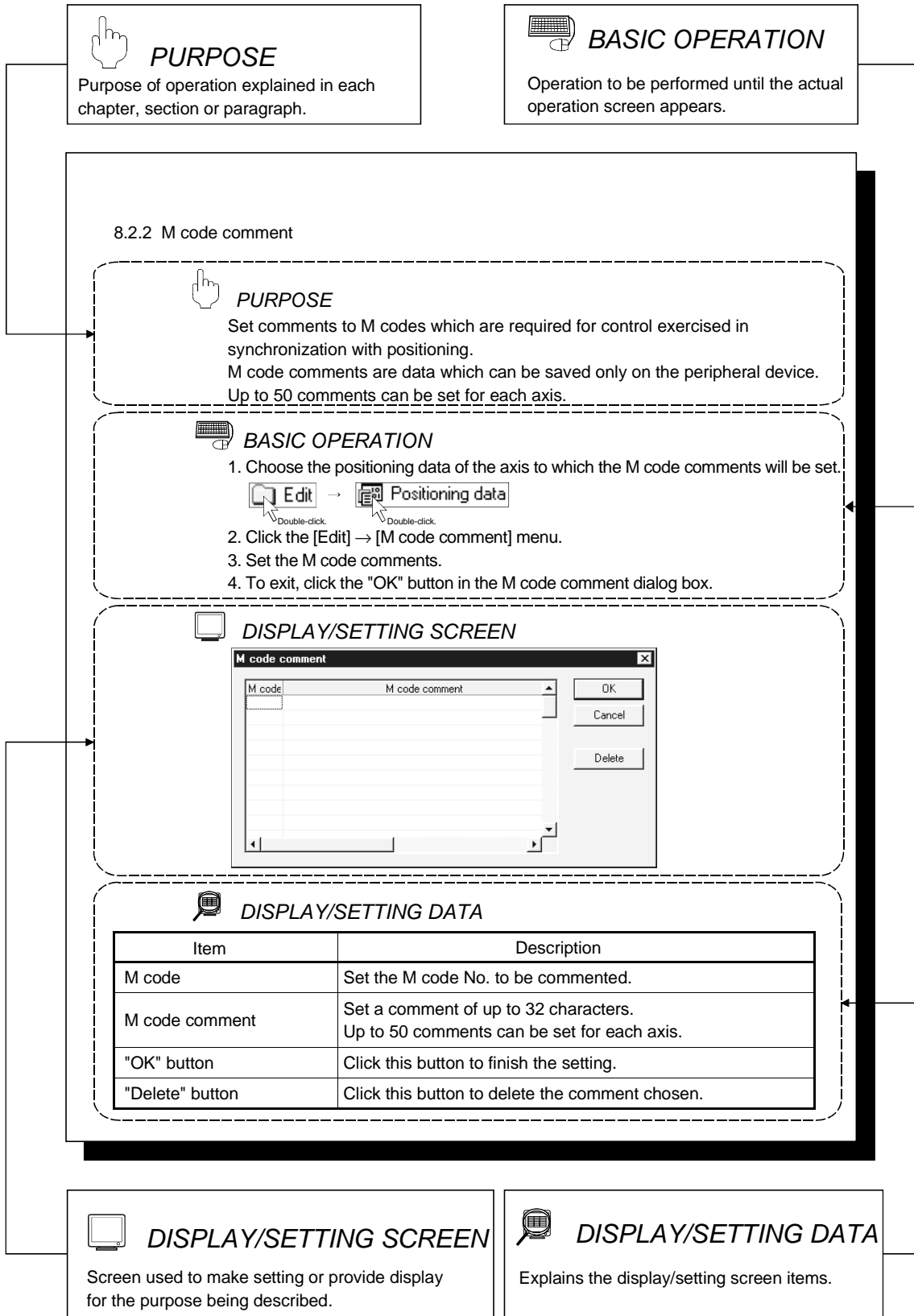

In addition, there are also the following explanations.



HELPFUL OPERATION

Describes application operation if there are multiple purposes and the basic operation and display/setting data do not provide enough information.





HELPFUL CORRECTIVE ACTIONS

Explains basic corrective actions if monitored data is abnormal or a test cannot be made.



Provides information relevant to that page, e.g. the items you should be careful of and the functions you should know.

The following table lists the symbols used in this manual and their definitions.

Symbol	Description
[]	Represents the menu name of the menu bar. If the menu name differs among Axes #1 to #4, they are indicated #1 to #4. [] → [] indicates a drop-down menu. Example: [Project] → [New Project] menu [Online] → [Test] → [Operation test #1 to #4] menu
()	Represents the tool button on the toolbar corresponding to the drop-down menu. If the button differs among Axes #1 to #4, the buttons of #1 to #4 are indicated. Example: [Project] → [Save Project] menu () [Online] → [Test] → [M code Off] → [M code #1 to #4 Off] menu ( to )
" "	Represents the item name or command button in the dialog box. Example: "OK" button
<< >>	Represents the tab in the dialog box. Example: <<Basic Parameter 1>> tab

About the Generic Terms and Abbreviations

The following generic terms and abbreviations for the positioning software packages, positioning modules, etc. are used in this manual.

Generic Term/Abbreviation	Description
SW□D5C-QD75P-E	Abbreviation for type SW0D5C-QD75P-E positioning module software package for MELSEC-Q series
SW□D5C-AD75P-E	Abbreviation for type SW0D5C-AD75P-E AD75 positioning module software package for MELSEC-A series
SW11VD-AD75P-E	Generic term for type SW11VD-AD75P-E positioning module software packages for MELSEC-A series
Peripheral device	Generic term for personal computers on which SW□D5C-QD75P-E may be used.
QD75	Generic term for type QD75P1, QD75P2, QD75P4, QD75D1, QD75D2 and QD75D4 positioning modules
AD75	Generic term for MELSEC-A series positioning modules that may be used with SW□D5C-AD75P-E
QD75 User's Manual	Abbreviation for the following relevant manual <ul style="list-style-type: none"> • Type QD75P1/QD75P2/QD75P4, QD75D1/QD75D2/QD75D4 Positioning Module User's Manual
Servo amplifier	Generic term for pulse input-compatible drive units that may be connected to the QD75
Servo motor	Generic term for motors connected to the drive units (servo amplifiers)
Positioning system	Generic term for equipment sets which exercise positioning control, including the positioning modules, servo amplifiers, servo motors and external switches

Packing List

This product consists of the following.

CD-ROM	SW0D5C-QD75P-E: 1 pc.
License key FD	SW0D5F-QD75PKEY-E: 1 pc.

1. OVERVIEW

This manual describes the functions and operating procedures of positioning module software package (hereinafter referred to as "SW□D5C-QD75P-E").

SW□D5C-QD75P-E is a positioning module software package which can perform the following functions via the QCPU, Q corresponding serial communication module or Q corresponding MELSECNET/H network remote I/O module.

- Setting of positioning data and parameters
- Simulation using positioning data
- Read/write of data from/to positioning module
- Monitoring of positioning control status
- Test operation of positioning control
- Automatic refresh setting between QCPU devices and QD75 buffer memory

SW□D5C-QD75P-E can be used with any of the following positioning modules.

Positioning Type	Type
Open collector output type	QD75P1, QD75P2, QD75P4
Differential driver output type	QD75D1, QD75D2, QD75D4

SW□D5C-QD75P-E can access the QD75 via any of the following modules.

Module Type	Type
QCPU	Q02CPU, Q02HCPU, Q06HCPU, Q12HCPU, Q25HCPU
Q corresponding serial communication module	QJ71C24, QJ71C24-R2
Q corresponding MELSECNET/H network remote I/O module *	QJ72LP25-25, QJ72BR15

* Only when connecting to the remote I/O module directly.

1.1 Features

(1) Concurrent editing of multiple projects

Capable of opening multiple projects simultaneously, this software allows you to easily edit the positioning data and block start data to be utilized by copying and pasting.

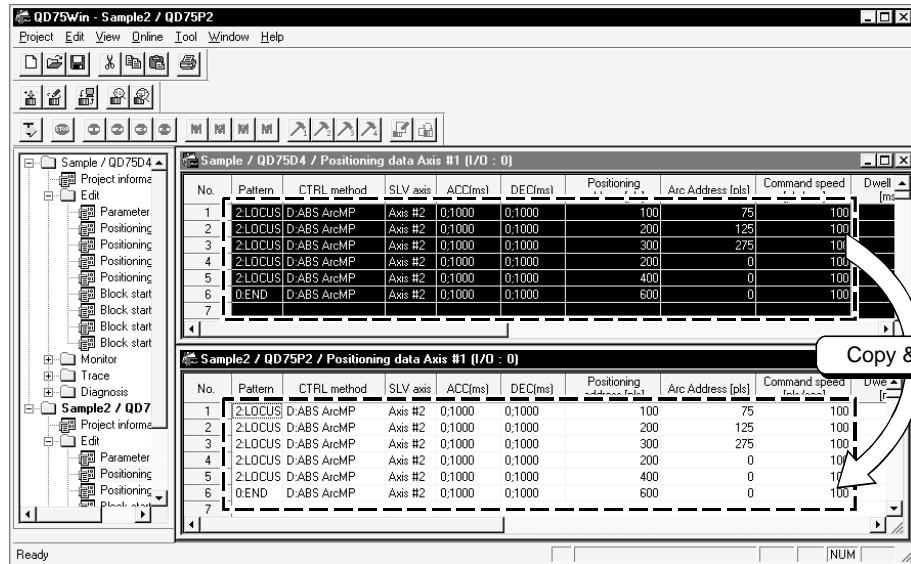

(2) Efficient debugging of multi-modules

Since SW-D5C-QD75P-E access to the QD75 is made via the QCPU, Q corresponding serial communication module or Q corresponding MELSECNET/H network remote I/O module *, a direct connection cable to the QD75 on the main/extension base unit is not needed.

Also, because the QD75 to be connected to is set per project, batch write to or monitoring of multi-modules can be performed.

When using multiple QD75s, you can reduce the software start waiting time and physical work time, increasing debugging efficiency.

* Only when connecting to the remote I/O module directly.

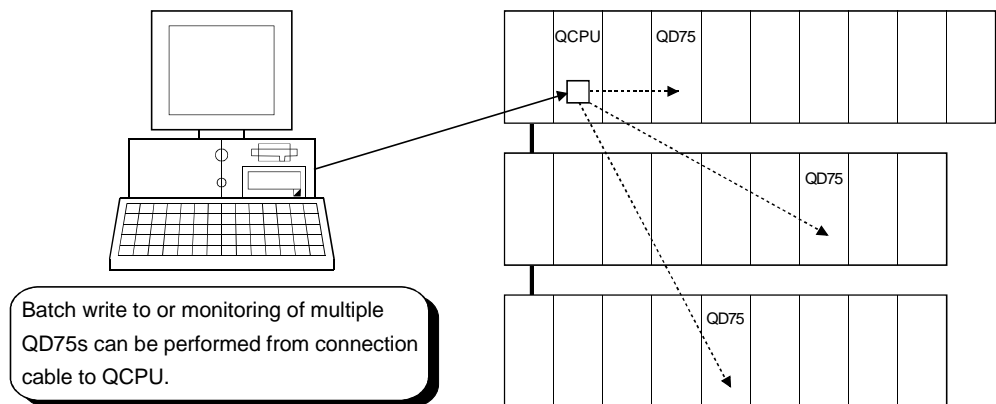

(3) Simplified sequence program by automatic refresh setting

Automatic refresh setting is made to automatically read the following values stored in QD75 buffer memory to the QCPU devices.

- Feed present value
- Machine feed value
- Feed speed
- Error No.
- Warning No.
- Enable M code

Automatic refresh setting reduces the number of FROM instructions used to read the buffer memory storage values, facilitating creation and debugging of sequence programs.

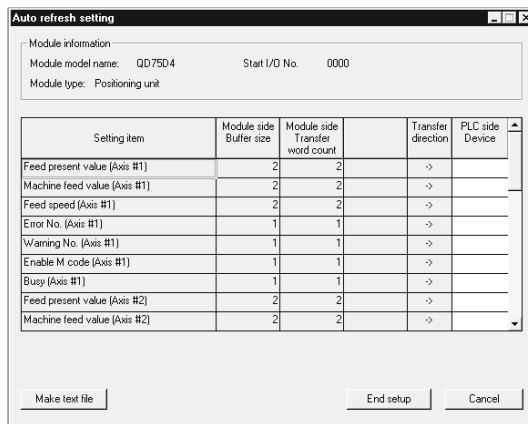

(4) Ease of operation with navigation function

SW-D5C-QD75P-E has a navigation function which can perform operations from data setting, write to the QD75, monitoring, test to data storage in a sequential order.

As basic settings and debugging can be performed in orderly sequence, you can understand operations necessary for this software package and positioning control.

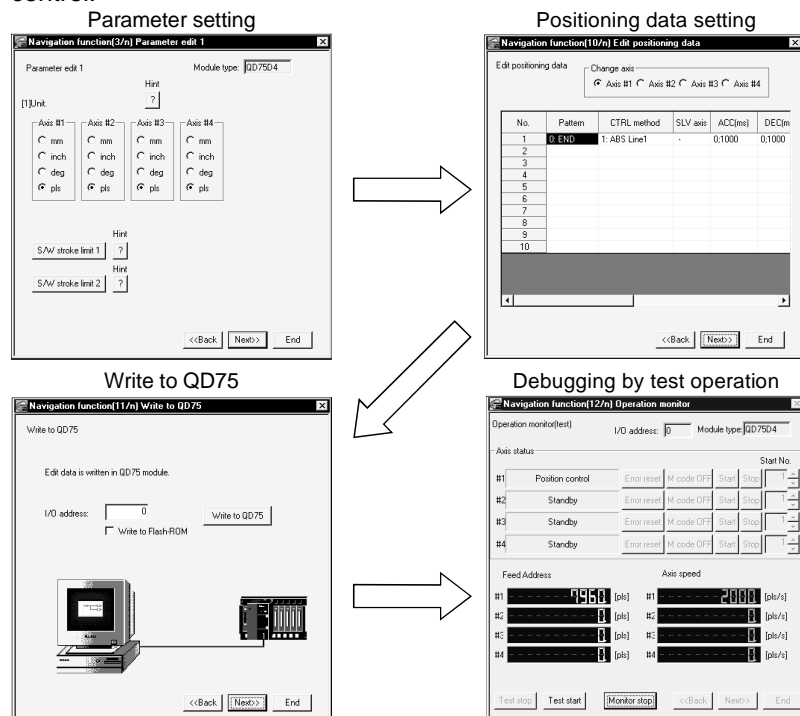

- (5) Setting of optimum positioning data without complicated calculation
 Positioning data can be set by sub arc setting and automatic axis speed setting.
 Sub arc setting generates from the specified two linear interpolation control data the circular interpolation control data in which the angle between two linear paths is converted into a circular arc (curve) path.
 Sub axis speed setting calculates the axis speed (command speed) from the operation time, travel, acceleration/deceleration time and motor specifications.

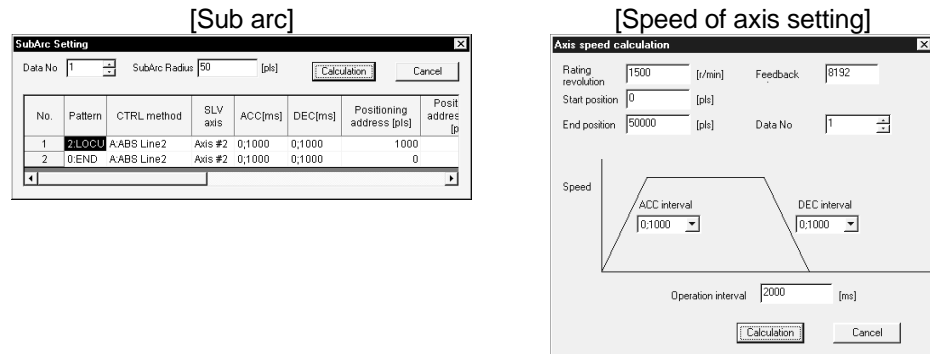

These functions allow the optimum positioning data to be set without complicated calculation and advance measurement.

- (6) Ease of migration from AD75
 You can read and use the data created on A series SW11VD-AD75P-E and SW0D5C-AD75P-E.
 Valuable data is not wasted and can be utilized for QD75.

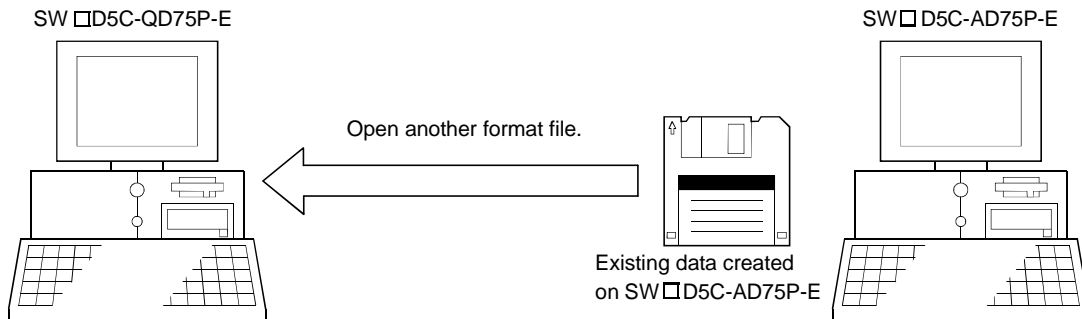

- (7) Versatility by compatibility with RS-232 and USB
 If the personal computer does not have a free serial port, connection can be made from the USB connector.
 Especially for a notebook computer having a few serial ports, there are no restrictions due to shortage of ports.

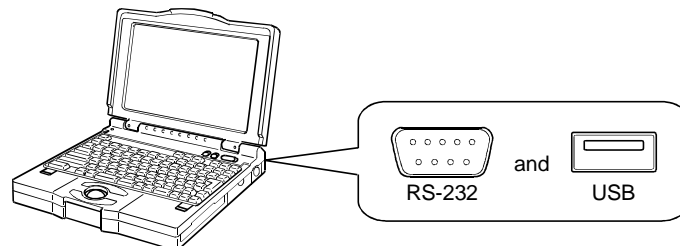

(8) Compatible with multiple PLC system

On SW□D5C-QD75P-E (Version 30D or later), setting the control PLC type and PLC No. of the QD75 to communicate with in Connection Setup (refer to Section 7.1) allows communication to be made with any QD75.

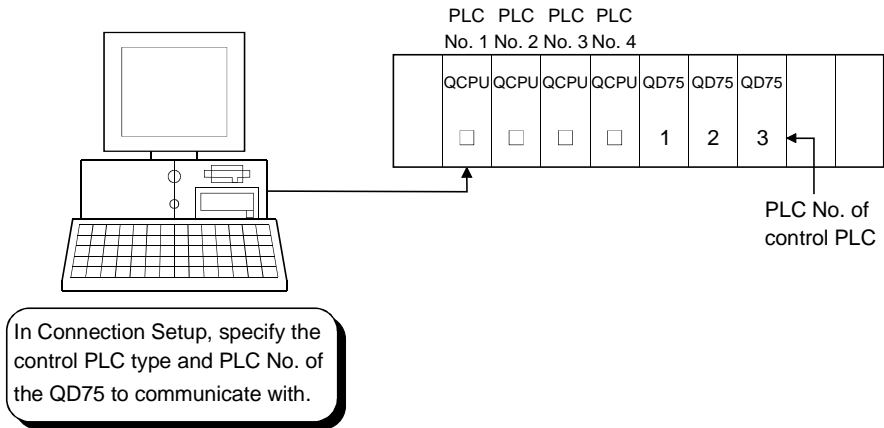

(Example)

Connection Setup for communication with the QD75 under control of PLC No. 1
 PLC type: Type of PLC No. 1, Multiple PLC setting: PLC No. 1

*:For details, refer to "QCPU (Q Mode) User's Manual (Function Explanation, Program Fundamentals)".

Point

- Communication with the QD75 cannot be made if the control PLC type and PLC No. of the QD75 to communicate with are not set correctly in Connection Setup.
- If correct settings have been made in Connection Setup, any of PLC No. 1 to No. 4 may be specified as the connection target of the connection cable.

1.2 Manual Makeup

This manual is made up of 11 chapters and appendices.

This manual assumes that SW□D5C-QD75P-E is used to perform steps from positioning system checking to operation in the following procedure.

<Sequence of steps taken by the user up to positioning system operation>

Step 1: Install and wire the positioning system.	Refer To
• Install and wire the PLC (such as the QCPU, QD75, I/O modules and intelligent function modules), servo amplifiers, motors, external switches and other external devices.	QD75 User's Manual



Step 2: Check the SW□D5C-QD75P-E functions and learn the basic operations.	Refer To
• Check the system with which SW□D5C-QD75P-E can be used.	Chapter 2
• Check the functions that can be performed by SW□D5C-QD75P-E.	Chapter 3
• Install SW□D5C-QD75P-E in the peripheral device and start the program.	Chapter 4
• Learn the SW□D5C-QD75P-E screen makeup and basic operations.	Chapter 5



Step 3: Start operation of SW□D5C-QD75P-E.	Refer To
• Create a project which will be the object of operation for SW□D5C-QD75P-E.	Chapter 6



Step 4: Check the connection and initial operation of the positioning system.	Refer To
• Specify the QD75 to be accessed, ports where cables will be connected, and others.	Chapter 7
• Check the QD75 types and I/O addresses of the stations connected.	
• Check connection according to the signal states from the external devices.	
• Check the alarms and warnings of the positioning module.	
• Check that the servo motors are run by JOG operation.	



(To the next page)

(From the preceding page)



Step 5: Set and write data to the positioning module.	Refer To
• Set the parameters appropriate for the positioning system and control.	Chapter 8
• Set the positioning data and M code comments.	
• Check the positioning data on the simulation screen.	
• Make the corresponding setting if block start data and/or condition data is required.	
• Make error check to check the parameters, positioning data and block start data settings.	
• Write, read or verify the set data on the project.	Chapter 9



Step 6: Perform test operation and check and adjust the settings.	Refer To
• Make online error check to recheck the settings of the parameters, positioning data and block start data written to the QD75.	Chapter 10
• Check positioning control and test on the monitor screen.	
• Set the positioning data and block start data, and perform test operation.	
• Make present value change test, speed change test, OPR test, JOG operation test and MPG operation test to check the parameters, addresses, axis speeds, etc.	



Step 7: Positioning system operation	Refer To
• Operate the positioning system with the PLC CPU program.	QD75 User's Manual

1.3 Additions/Modifications Function according to SW0D5C-QD75P-E Versions

Additions/Modifications Functions for each Versions of SW0D5C-QD75P-E are given below.

Function *1	Versions of SW0D5C-QD75P-E *2		Reference
	Version 30D or later	Version 20C or below	
Connection Setup • Addition of PLC No. setting of multiple PLC *3 (for multiple PLC system) • Addition of Q corresponding MELSECNET/H network remote I/O module *4 connection setup	Yes	No	Section 7.1
Addition of parameter for speed-position switching control (ABS mode) *5 <Speed-position function selection>	Yes	No	Section 8.1
Signal monitoring for pre-reading start function *5 <Y14: Axis #1 execution prohibition flag> <Y15: Axis #2 execution prohibition flag > <Y16: Axis #3 execution prohibition flag > <Y17: Axis #4 execution prohibition flag >	Yes	No	Section 10.2.4

*1:Compatible with the function version "B" of the QD75. For confirmation of the QD75 function version, refer to "Section 7.3 Checking the QD75 Function Version (OS Information)".

*2:For confirmation of the SW0D5C-QD75P-E version, refer to "Section 11.10 Help".

*3:For details, refer to "QCPU (Q Mode) User's Manual (Function Explanation, Program Fundamentals)".

*4:For details, refer to "Q Corresponding MELSECNET/H Network System Reference Manual (Remote I/O Net)".

*5:For details, refer to "QD75 User's Manual" (SH-080058-B or later).

2. SYSTEM CONFIGURATION

2.1 System Configuration

(1) Overall configuration of this system

(a) Via QCPU, Q corresponding serial communication module

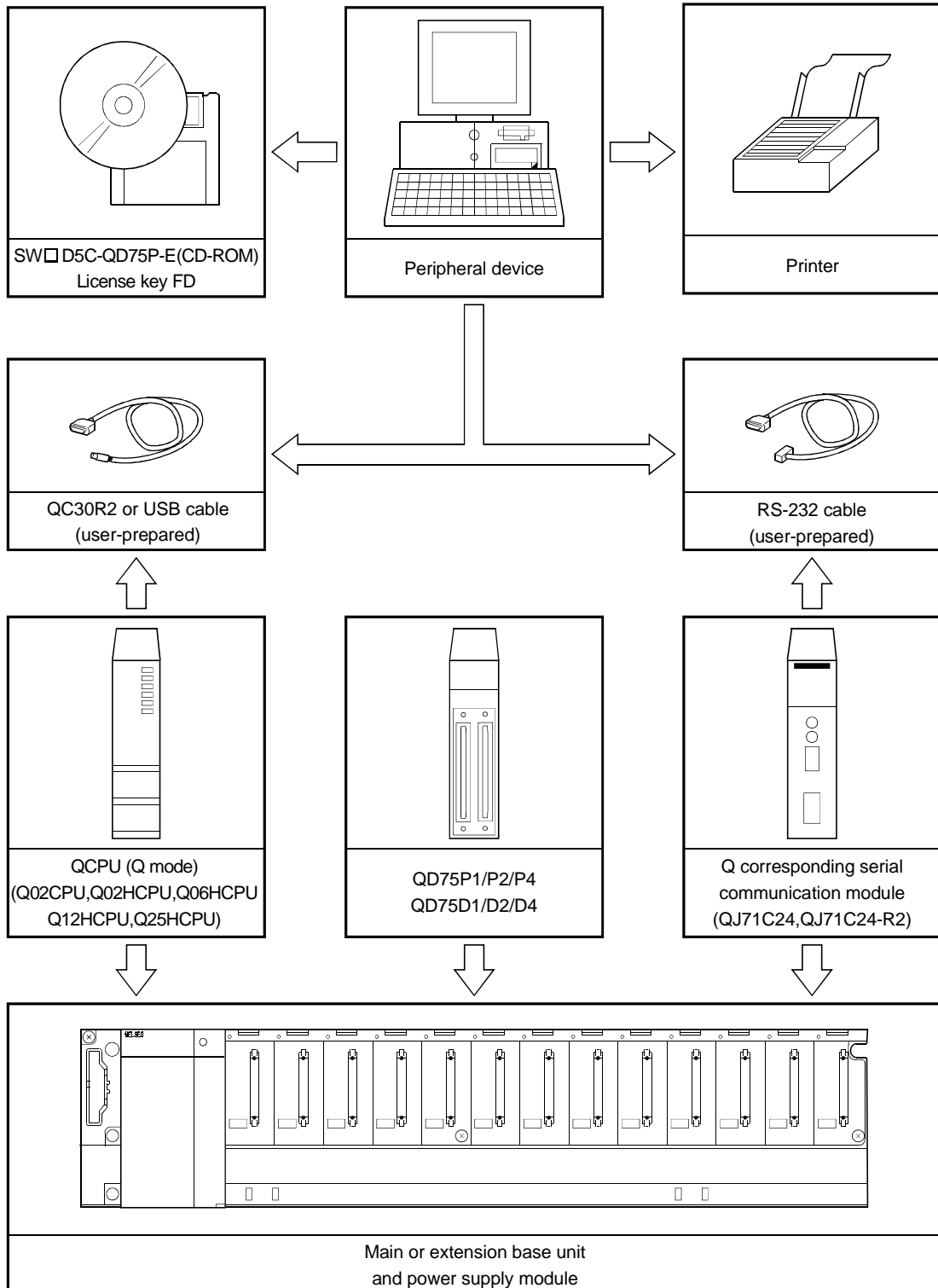

(b) Connecting to Q corresponding MELSECNET/H network remote I/O module directly

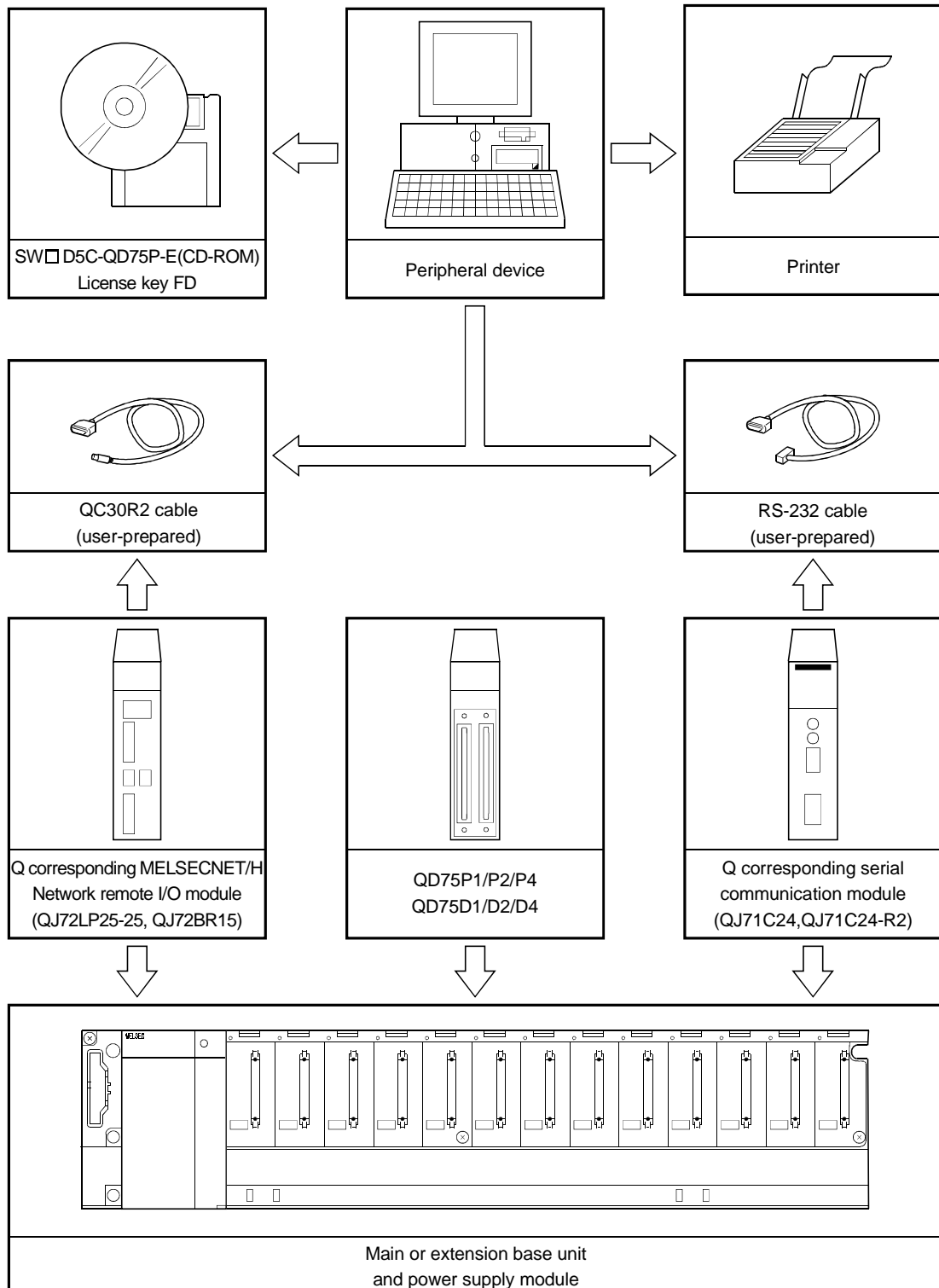



- Do not connect a peripheral device to the Q corresponding serial communication module by multidrop link.
- Concurrent use of this product on multiple personal computers is illegal. Therefore, this product may only be used on the personal computer specified in the software registration card. However, to prepare for any unexpected situation, e.g. hard disk crash of the personal computer, the license key FD is designed to be installable up to five times. When you use the FD on another personal computer, you regain one installation right by uninstalling the license key FD. (i.c. number of allowable installations increases by one.)
- By installing the license key FD, the product can be started. (Refer to Section 4.1.)
- Ensure the computer that the FD license key has been installed on is easily identifiable, and store the FD safely. If you mislay the license key FD or the license key FD does not match the personal computer where it has been installed, it cannot be installed or uninstalled.

(2) About the connection cables

(a) Connection to QCPU or Q corresponding MELSECNET/H network remote I/O module by QC30R2 (made by Mitsubishi Electric)

When the baudrate is set to 115.2/57.6kbps, communication cannot be made unless the peripheral device used is compatible with the communication speed of 115.2/57.6kbps.

If a communication error occurs, reduce the baudrate setting and restart communication.

(b) Connection to QCPU by USB cable

- Usable when Microsoft® Windows® 98 Operating System or USB driver has been installed.
- Unusable for Microsoft® Windows® 95 Operating System or Microsoft® WindowsNT® Workstation 4.0 Operating System.
- Use of the USB cable allows only PLC CPU to be connected.

(c) Connection to Q corresponding serial communication module

The specifications of the RS-232 cable connector are indicated below.

Pin Number	Signal Code	Signal Name	Signal Direction
			Q corresponding serial communication module ↔ external device
1	CD	Receive carrier detection	←
2	RD(RXD)	Receive data	←
3	SD(TXD)	Send data	→
4	DTR(ER)	Data terminal ready	→
5	SG	Send ground	↔
6	DSR(DR)	Data set ready	←
7	RS(RTS)	Request to send	→
8	CS(CTS)	Clear to send	←
9	RI(CI)	Call indication	←

• Connection example which can turn ON/OFF CD signal (No. 1 pin)

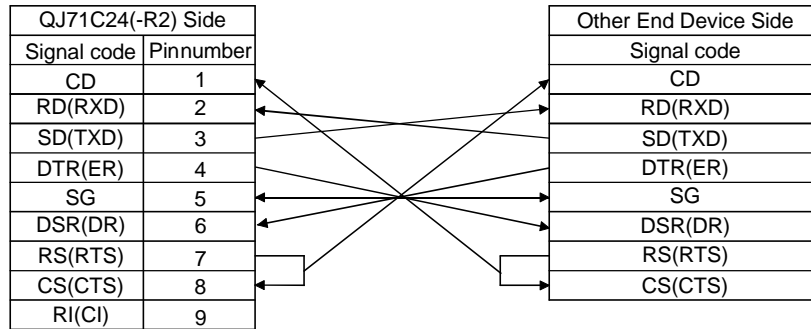

• Connection example which cannot turn ON/OFF CD signal (No. 1 pin)

Connection example for exercising DC code control or DTR/DSR control

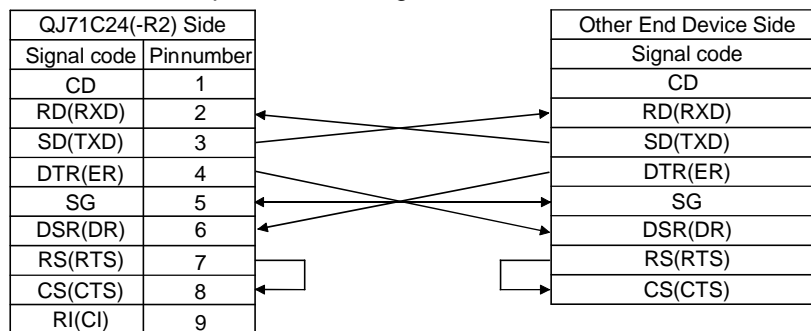

2.2 Operating Environment

Operate the system in the following environment.

Item	Description
Peripheral device	Personal computer with Pentium® 133MHz or more (recommended) CPU and Windows® 95 upwards.
System software	Microsoft® Windows® 95 Operating System (English version), Microsoft® Windows® 98 Operating System (English version) or Microsoft® WindowsNT® Workstation 4.0 Operating System (English version)
Required memory	32MB or more recommended
Hard disk free space	40MB or more
Disk drive	3.5 inch (1.44MB) floppy disk drive CD-ROM disk drive } Disk drive required
Display	Resolution of 800 × 600 pixels or more



- To install the license key FD requires a 3.5 inch (1.44MB) floppy disk drive.
 - Instructions for use of PDF data
- To ensure comfortable operation, ensure the computer has sufficient memory.

3. FUNCTION LIST

3.1 Function List

(1) Function list

The main functions of SW□D5C-QD75P-E are listed.

Function		Description	
Edit	Parameter setting	Sets the basic parameters #1, basic parameters #2, extended parameters #1, extended parameters #2, OPR basic parameters and OPR extended parameters.	
	Positioning data setting	Sets the positioning data, such as pattern, control method, accel/decel time and address, on an axis basis.	
	M code comment setting	Sets comments to the M codes assigned to the positioning data on an axis basis.	
	Sub arc	Automatically generates positioning data to ensure smooth movement on the intersection of consecutive two-axis linear interpolations by circular interpolation.	
	Automatic axis speed setting	Automatically calculates the axis speed in the constant-speed part by setting the time taken from a positioning start until the target position is reached.	
	Block start data setting	Sets the starting mode, etc. of the positioning data specified for points on an axis basis.	
	Condition data setting	Sets the data which is used as a special start condition in the block start data on an axis basis.	
	Simulation	Simulates axis operation from the setting positioning data. Wave form data is displayed for single axis control. Locus data is displayed for two axis interpolation control.	
Monitor	Positioning monitor	Enters the monitor mode from the positioning data edit window and monitors the positioning data during operation.	
	Block start monitor	Enters the monitor mode from the block start data edit window and monitors the block start data during operation.	
	Operation monitor	Monitors the operating states, such as feed present values, axis feed speeds, axis statuses and executed positioning data numbers, of all axes.	
	History monitor	Monitors the error, warning, start history of all axes.	
	Signal monitor	Monitors the X/Y devices, external signals or status signals of all axes.	
	Operation monitor	Monitors the control states, QD75 parameter settings or others of all axes.	
	Sampling monitor	Signal Monitors the specified signals while simultaneously sampling them. Buffer memory Monitors the specified buffer memory data while simultaneously sampling them.	
	System monitor	Shows the system configuration of the host and the I/O address and model (type) of the specified QD75.	
Test	Cableless mode	Tests the QD75 alone without wiring between the servo amplifier and motor.	
	Positioning data test edit	Writes the setting parameters, positioning data and block start data in the test mode.	
	Operation test	Positioning start	Specifies the positioning data number and block start data point number and performs test operation.
		Present value change	Performs the change test of the feed present value.
		Speed change	Performs a speed change test on the axis on which a positioning start test is being done.
		OPR	Performs an original point return test.
		JOG operation	Performs a JOG operation test.
		Inching operation	Moves the axis over the specified distance per operation.
MPG operation	Performs test operation using a manual pulse generator.		

Function		Description
Diagnosis	Checking connect	Initializes the QD75 and displays signals from external devices. Also tests initial operation by JOG operation.
Trace	Waveform display	Traces the speed command for a given time and displays the waveform data relative to the time axis.
	Locus display	Traces the position command or real value for a given time and displays the track data of the axes.
Extended	Automatic refresh setting	Assigns the QD75 buffer memory and QCPU devices for automatic refresh between QD75 and QCPU.
	Navigation	Performs operations from parameter and positioning data settings to simple test operation and set data storage in accordance with navigation.

3.2 Menu list

The menu bar drop-down menus are listed below.

<p>Project</p> <ul style="list-style-type: none"> - New Project Section 6.1 - Open Project Section 6.2 - Close Project Section 6.4 - Save Project Section 6.3 - Save as Project Section 6.3 - Delete Project Section 6.5 - Verify Project Section 11.1.1 - Import file <ul style="list-style-type: none"> - File reading of SW11VD-AD75P-E Section 6.6.1 - File reading of SW0D5C-AD75P-E Section 6.6.1 - File reading of CSV form positioning data Section 6.6.2 - File reading of Trace data Section 11.8.2,11.9.2 - Export file <ul style="list-style-type: none"> - File writing of CSV form positioning data Section 6.7 - File writing of Trace data Section 11.8.2,11.9.2 - Change QD75 model Section 11.1.2 - Printing Section 11.6.2 - Printer setting Section 11.6.1 - Latest file Section 6.2 - Exit Section 4.4 <p>Edit</p> <ul style="list-style-type: none"> - Cut Section 11.2.1 - Copy Section 11.2.1 - Paste Section 11.2.1 - Select All Section 11.2.1 - Jump Section 11.2.2 - Clear row Section 11.2.3 - Clear column Section 11.2.3 - Axis copy Section 11.3.1 - Block start copy Section 11.3.2 - M code comment Section 8.2.2 - Condition data Section 8.4.2 - Simulation Section 8.3 - Sub arc Section 8.2.1 - Speed of axis setting Section 8.2.1 <p>View</p> <ul style="list-style-type: none"> - Project tree view Section 5.2 - Toolbar Section 5.2 - Test toolbar Section 5.2 - Status bar Section 5.2 - Online toolbar Section 5.2 - Select block start no. Section 8.4.1 	<p>Online</p> <ul style="list-style-type: none"> - Connection Setup Section 7.1 - Read from QD75 Section 9.1 - Write to QD75 Section 9.1 - Multi-module batch write Section 11.1.4 - Verify QD75 data Section 9.1 - Error check QD75 data Section 10.1 - OS information Section 7.3 - Flash ROM write request Section 9.2 - QD75 Initialization Section 9.3 - Monitor <ul style="list-style-type: none"> - Monitor On/Off Section 10.2,10.3 - Test <ul style="list-style-type: none"> - Test On/Off Section 10.4 - Positioning data test edit Section 11.7.2 - Teaching Section 11.7.1 - Cable less test mode Section 10.4 - Operation test <ul style="list-style-type: none"> - Operation test #1 Section 10.4.1 - Operation test #2 Section 10.4.1 - Operation test #3 Section 10.4.1 - Operation test #4 Section 10.4.1 - Error reset <ul style="list-style-type: none"> - Error reset #1 Chapter 10 - Error reset #2 Chapter 10 - Error reset #3 Chapter 10 - Error reset #4 Chapter 10 - M code off <ul style="list-style-type: none"> - M code off #1 Chapter 10 - M code off #2 Chapter 10 - M code off #3 Chapter 10 - M code off #4 Chapter 10 - All axis stop Chapter 10 - Tool <ul style="list-style-type: none"> - Error check Section 8.5 - Initializing the data Section 11.2.4 - Navigation Section 11.4 - System monitor Section 7.2 - Intelligent function utility Section 11.1.3 - Option Section 11.5 - Window <ul style="list-style-type: none"> - Cascade Section 5.7 - Tile vertically Section 5.7 - Arrange icons Section 5.7 - All close Section 5.7 - Help <ul style="list-style-type: none"> - QD75Win Help Section 11.10 - Error/Warning/List of Buffer memory Section 11.10 - About (QD75Win) Section 11.10
--	--

4. INSTALLATION AND UNINSTALLATION

This chapter describes how to install and uninstall SW□D5C-QD75P-E.

4.1 Installation

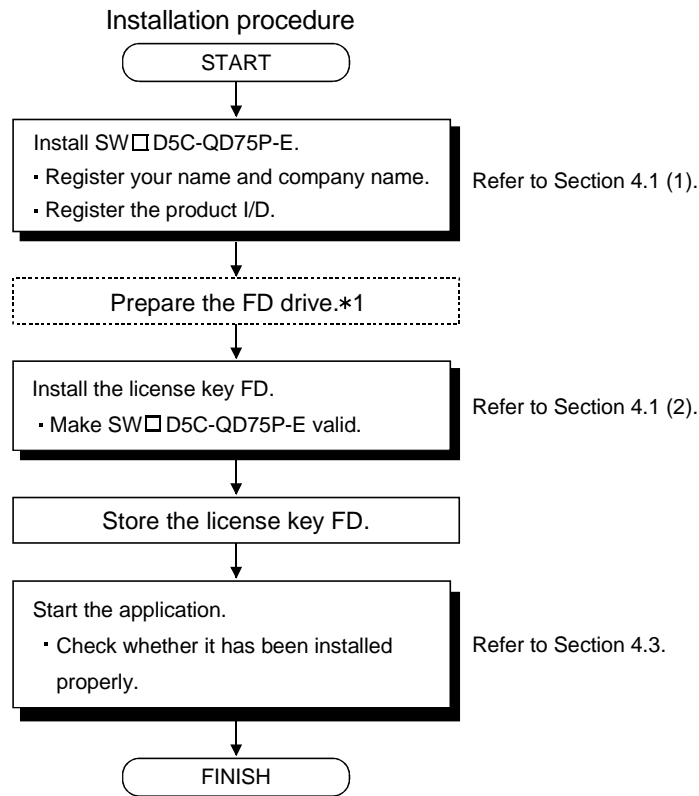

4

Point

*1: For a notebook computer designed to change a CD-ROM drive for an FD drive and vice versa, make this change after installation of the application is complete.
After the peripheral device has been restarted, the license key FD can be installed.

Never perform the following operations for the license key FD.
The license key FD will be damaged if any of the following operations is performed.

- FD formatting
- File write onto the FD
- FD file copy (copy to other drive, copy from other drive)
- Deletion of file on the FD, file name changing, file attribute changing
- Running analysis tool (e.g. SCANDISK) for the FD

(1) Installing SW□D5C-QD75P-E

The following explains how to install SW□D5C-QD75P-E.

Point

- Before starting installation, close all other applications running on Microsoft® Windows® Operating System.
- When the Operating System is Microsoft® WindowsNT® Workstation 4.0 Operating System, log on as a user who has the attribute of an administrator (for computer management).

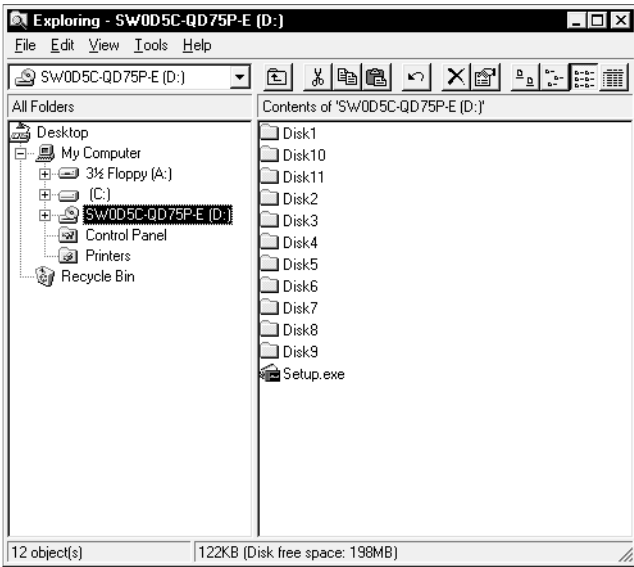

1) Start Explorer and click the drive where the disk is inserted.

Double-click "Setup.exe".

To display Explorer, choose [Start] → [Programs] → [Windows Explorer].

When uninstallation has not been performed (license invalid)

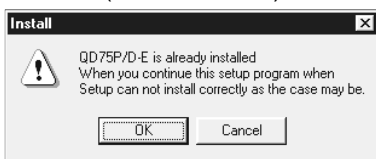

When the message shown on the left has appeared, click the "Cancel" button, uninstall and then reinstall the product.

When uninstallation has not been performed (license valid)



When the message shown on the left appears, restore the license using the license key FD and then install the product.

(To the next page)

(From the preceding page)

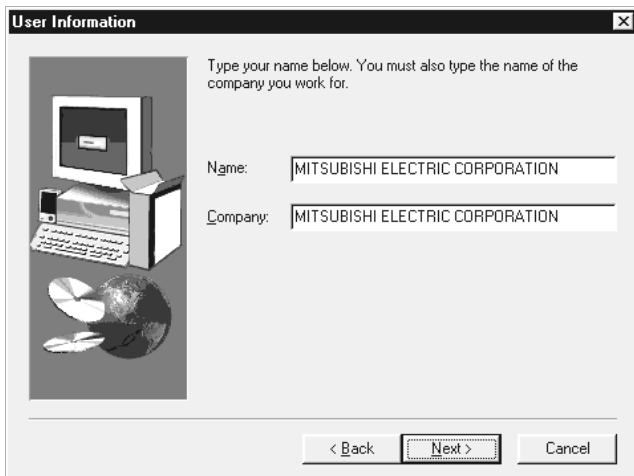

2) Type your name and company name, and click the "Next>" button.

As the confirmation dialog box appears, follow the messages and perform operation.



3) Enter the product ID and click the "Next>" button.

The product ID is given on the "Software Registration Card".

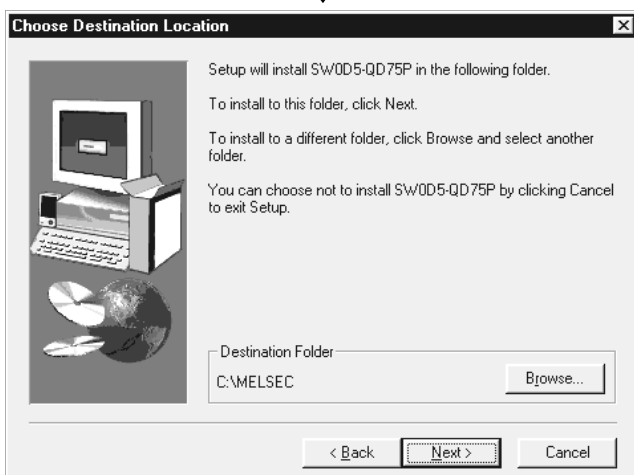

4) Specify the installation destination folder.

After specifying the installation destination folder, click the "Next>" button.

It defaults to "C:\MELSEC".

To change the destination folder, click the "Browse..." button and specify a new drive and folder.

(To the next page)

(From the preceding page)

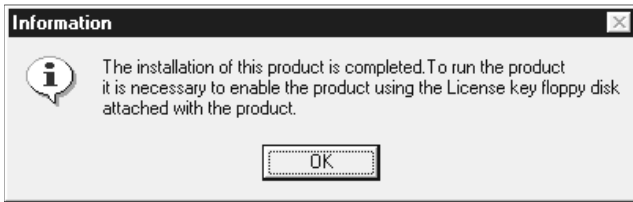

5) This completes installation.

Now install the license key FD and set the product to valid status.



When the message shown on the left appears, Windows® must be restarted.

Point

- If installation failed at any point in the above procedure, uninstall and reinstall the program.

Installing SW□D5C-QD75P-E registers the icon as shown below.

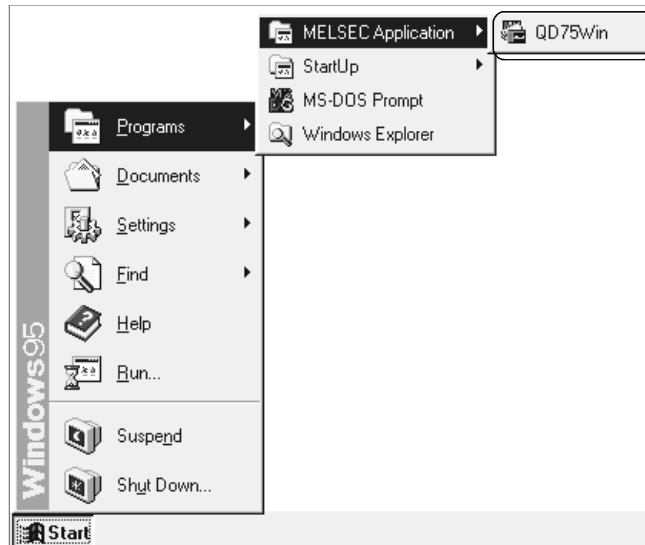

(2) Installing the license key FD

The license key FD is designed to make SW□D5C-QD75P-E valid.

After installing SW□D5C-QD75P-E, install the license key FD to make SW□D5C-QD75P-E startable.

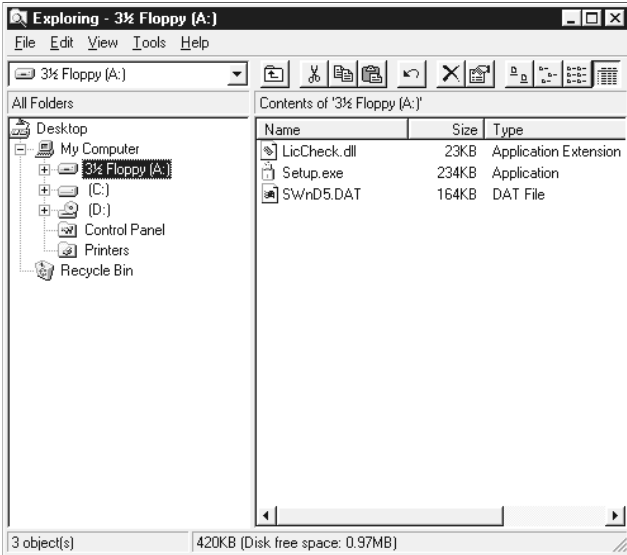

- 1) Start Explorer and click the drive where the disk is inserted.
Double-click "Setup.exe".
To display Explorer, choose [Start] → [Programs] → [Windows Explorer].



- 2) Click the picture of the lock.



- 3) Click the "Close" button.
(When the picture of the open lock appears, SW□D5C-QD75P-E can be started.)

4.2 Uninstallation

This section explains the operation for removing SW□D5C-QD75P-E from the hard disk.

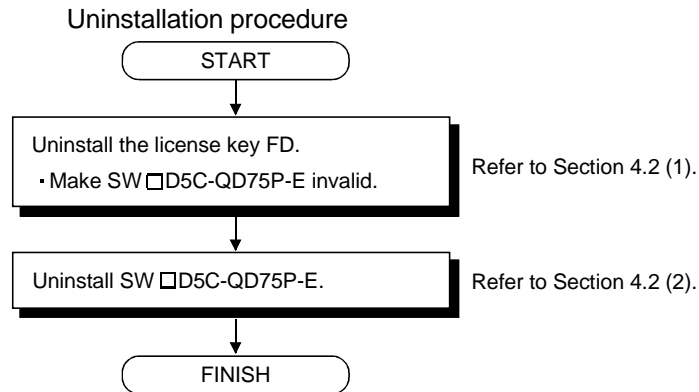

- Uninstallation requires the same license key FD as used for installation.

(1) Uninstalling the license key FD

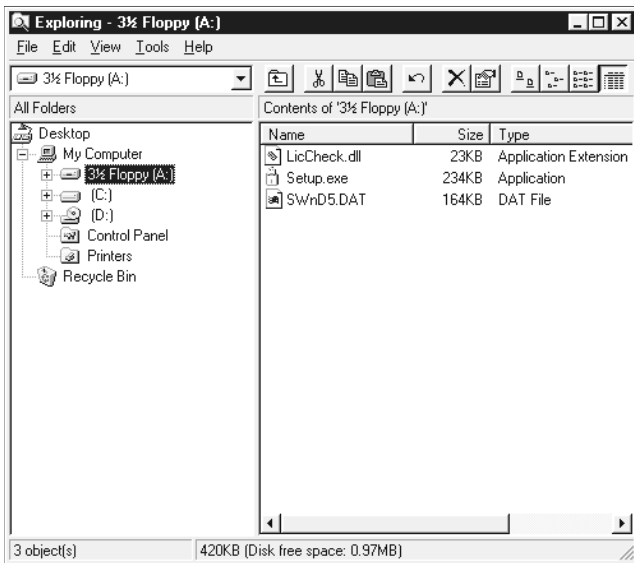

- 1) Start Explorer and click the drive where the license key FD is inserted. Double-click "Setup.exe". To display Explorer, choose [Start] → [Programs] → [Windows Explorer].



- 2) Click the picture of the open lock.



- 3) Click the "Close" button. (When the picture of the closed lock appears, the product is made invalid and can be uninstalled.)

(2) Uninstalling SW□D5C-QD75P-E

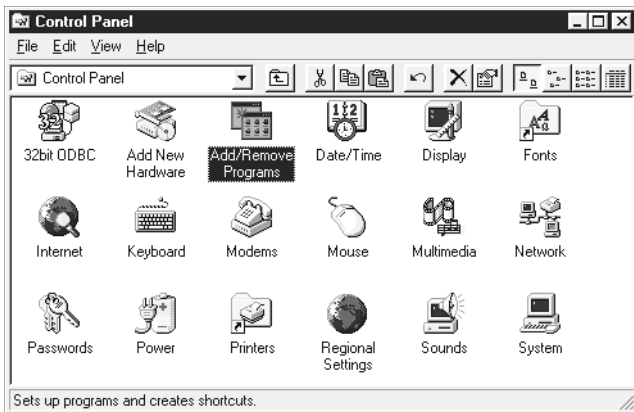

- 1) Double-click "Add/Remove Programs" on the Control Panel.
To display the Control Panel, choose [Start] → [Settings] → [Control Panel].

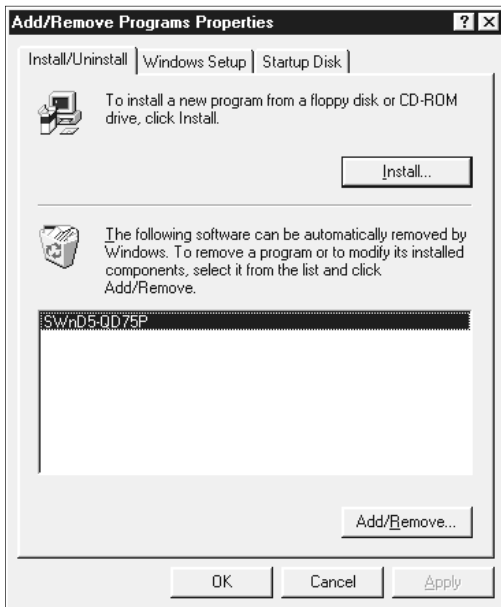

- 2) Choose "SWnD5-QD75P".

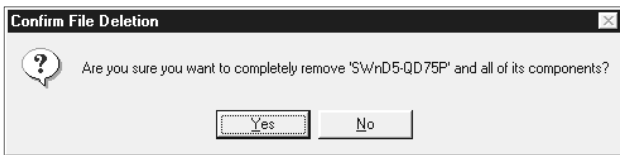

- 3) Confirm that SW□D5C-QD75P-E will be removed.
Click "Yes" to start uninstallation.
Click "No" to return to the previous screen.

(To the next page)

* Components indicate the installed icon and file. Unless you make SW□D5C-QD75P-E invalid with the license key FD, the following dialog box appears.

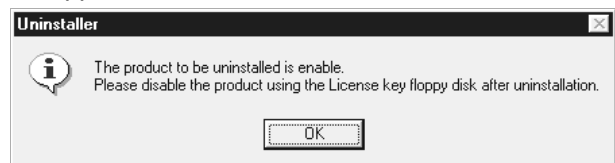

(From the preceding page)

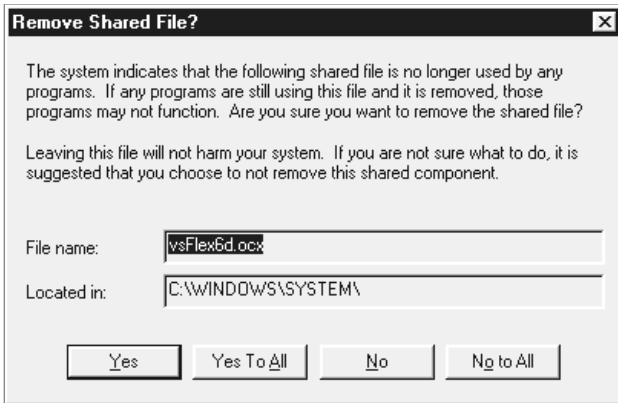

4) If the left screen has appeared, click the "No to All" button.

If you choose "Yes" or "Yes to All", the shared files for other MELSEC software packages are removed. To remove only SW□D5C-QD75P-E, therefore, click the "No to All" button.

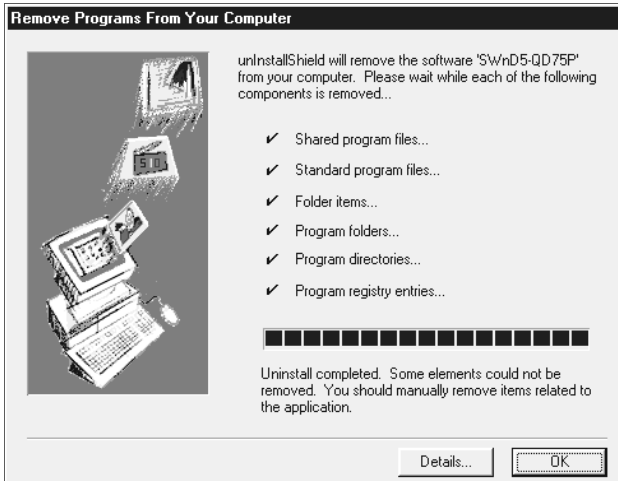

5) When the "Uninstall completed" message appears, click the "OK" button.

The completed message indicates that uninstallation is complete.

4.3 Starting SW□D5C-QD75P-E

This section explains how to start SW□D5C-QD75P-E from the start menu.

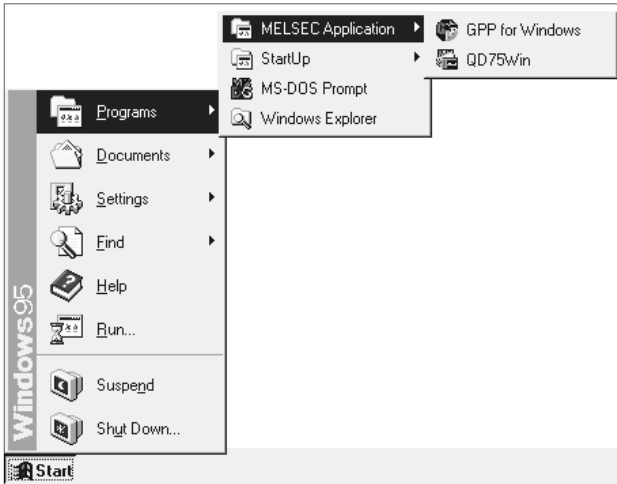

1) Move the cursor from [Start] → [Programs] → [MELSEC Application].

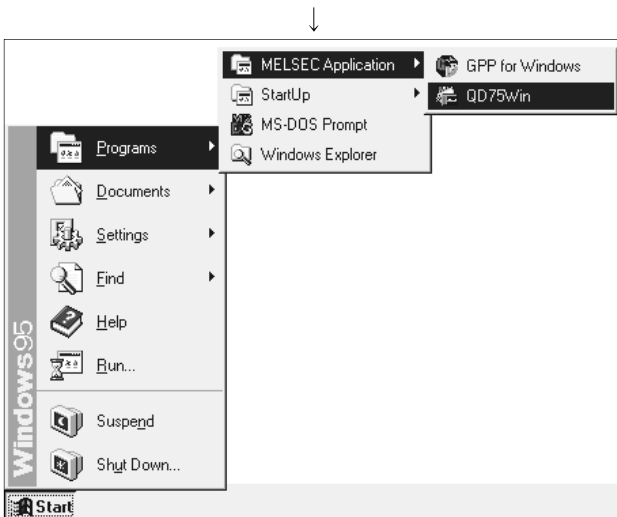

2) Click [QD75WIN].

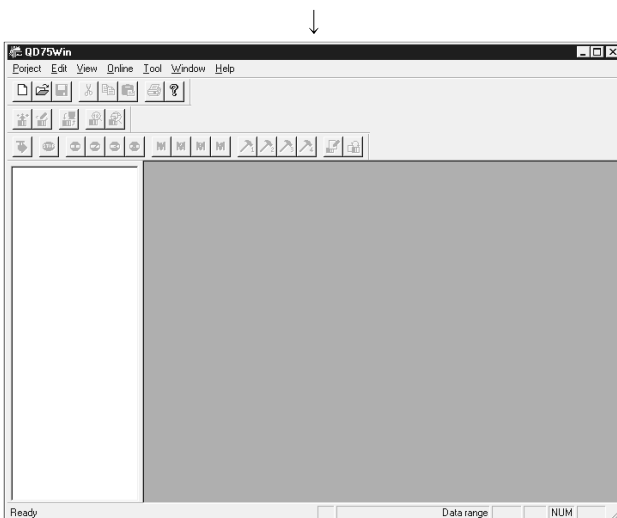

3) SW□D5C-QD75P-E starts.

4.4 Exiting SW□D5C-QD75P-E

This section describes how to exit SW□D5C-QD75P-E.

(1) Menu-driven exit method

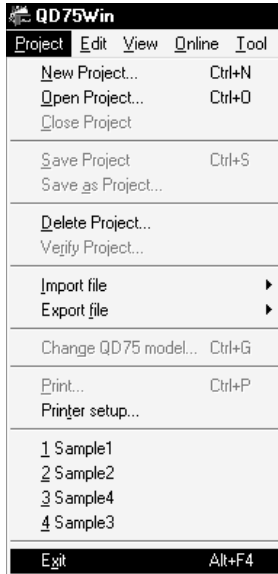

Click the [Project] → [Exit] menu.
SW□D5C-QD75P-E ends.

(2) Title bar-driven exit method



Click and choose [Close].
Alternatively, click at the right end of the title bar.



- In the online status such as the monitor or test mode, you cannot exit SW□D5C-QD75P-E.
In any of the following cases, end the program after choosing the offline status.
Monitor mode (refer to Section 10.2)
Test mode (refer to Section 10.4)
Online status for checking connect (refer to Section 7.4)

REMARK

When a new project has been created or a project has been modified but is not yet saved, the confirmation dialog box appears to ask you whether you will save that project or not.

When you do not want to save it, click the "No" button.

When you want to save it, click the "Yes" button.

When you save a new project, choose [Save as Project].

For further information, refer to Section 6.1.

MEMO

5. SCREEN MAKEUP AND BASIC OPERATIONS

This chapter explains the screen makeup and the display selection, window arrangement and other operations of SW□D5C-QD75P-E.

5.1 Screen Makeup and Display Selection

This section provides the screen makeup of SW□D5C-QD75P-E.

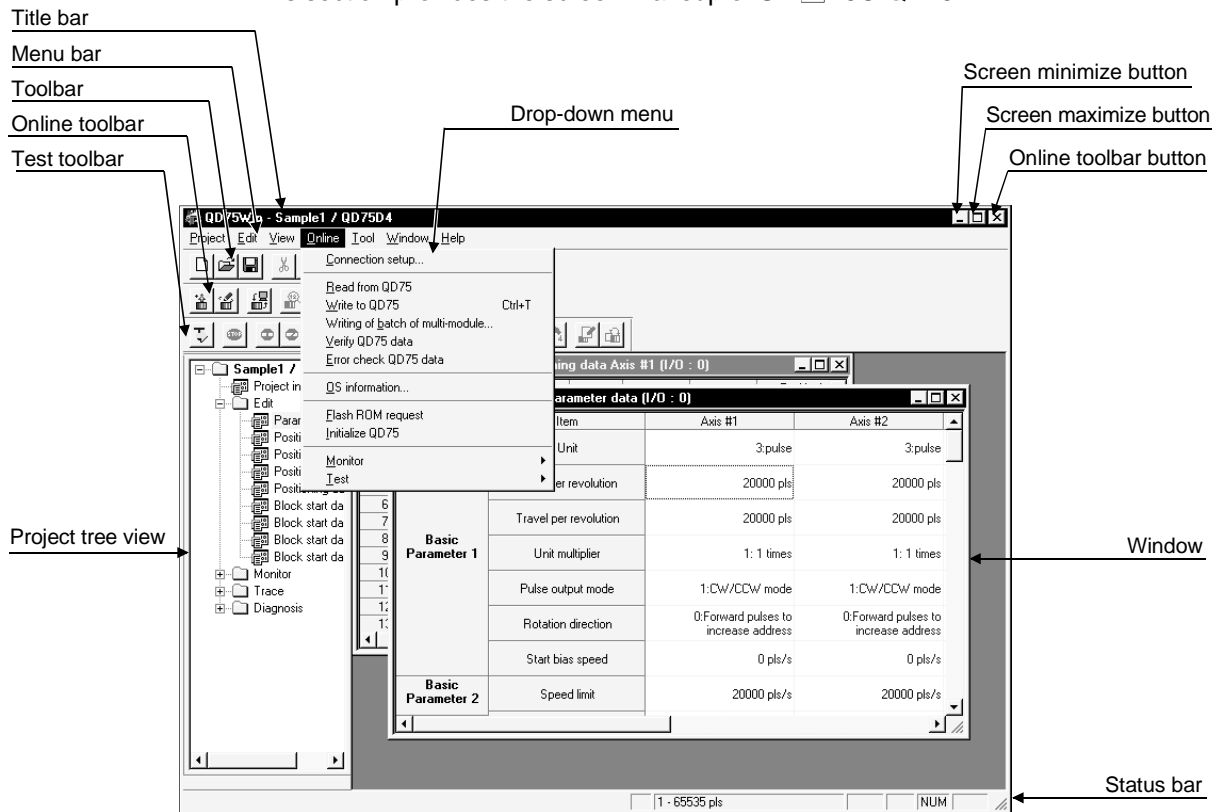

5

(1) Display selection and window arrangement operations

You can use the following drop-down menu to choose to display or hide any toolbar or arrange windows.

Menu Operation	Description
[View] → [Project tree view] [Toolbar] [Test toolbar] [Online toolbar]	Used to display or hide the corresponding toolbar.
[View] → [Status bar]	Used to display or hide the status bar.
[View] → [Select block start no]	Used to choose any of block numbers 0 to 4 to be displayed on the block start data edit window. (Refer to Section 8.4.1)
[Window] → [Cascade]	Used to overlap multiple windows. The above screen gives a cascade example
[Window] → [Tile vertically]	Used to lay multiple windows side by side.
[Window] → [Arrange icons]	Used to arrange windows which have been reduced to small icons (minimized).
[Window] → [All close]	Used to close all open windows.

5.2 Basic Operations

(1) Basic operation for project tree view

(a) Opening a window

The currently open project appears on the project tree view. Double-click the project name or click to show its functions. (From the keyboard, choose the project name and press the "→" key.)

Double-click the function name or click to show the window types. (From the keyboard, choose the function name and press the "→" key.)

Double-click the window name to open that window.

(From the keyboard, choose the window name and press the "Space" key.)

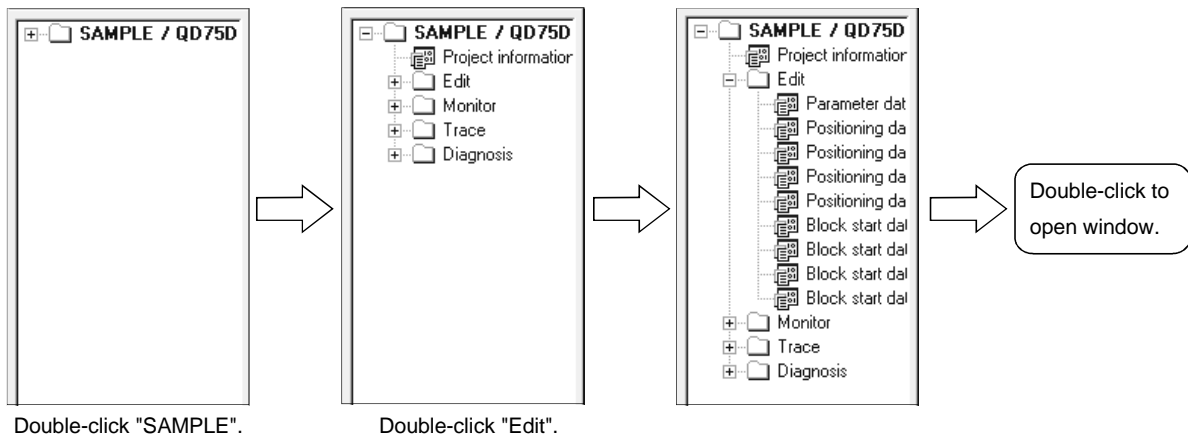

(b) Changing the active project

Any online operation except for monitor, sampling (signal) monitor and sampling (buffer) monitor is performed for the QD75 to which the active project is connected, separately from the active window.

To change the active project, right-click the project name and click [Set Active Project].

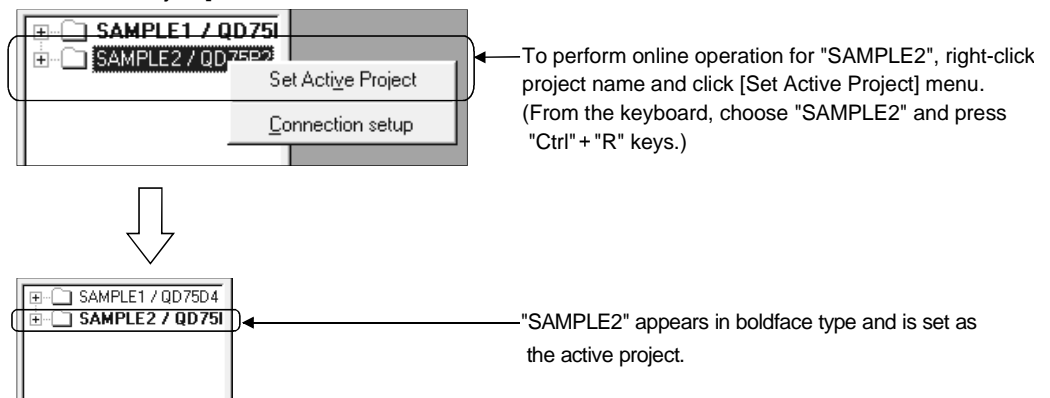

Point

When multiple projects are open, confirm the active project before starting any online operation except for monitor, sampling (signal) monitor and sampling (buffer) monitor.

(2) Basic operation for dialog boxes

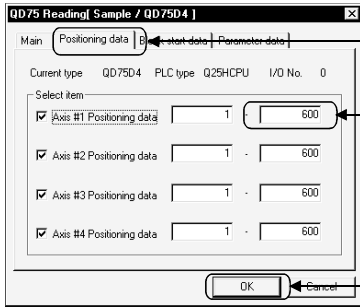

- 1) Tab
- 2) Text box
- 3) Command button

- 1) Tab
Click the setting item name to select.
- 2) Text box
Type numerals/characters.
- 3) Command button
Click this button when executing "OK", "Cancel" etc., or when displaying the dialog box.

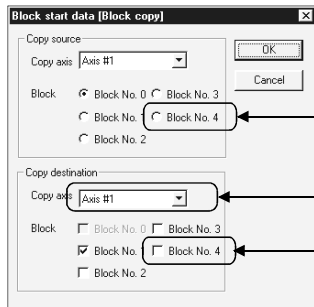

- 4) Radio button
- 5) List box
- 6) Check box

- 4) Radio button
Click to choose one item among multiple choices.
- 5) List box
Click to list choices, then click the item to be chosen.

- 6) Check box
To execute any item, click to check it off.

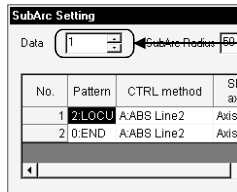

- 7) Spin box

- 7) Spin box
Used either to type a value directly or to change a value by clicking .
When typing a value directly, click inside the spin box and enter the value from the keyboard.
When clicking to change a value, click to increase the value, or click to decrease.

REMARK

When performing operation from the keyboard, choose the setting item with the "Tab" key.

When there are two or more choices, use the "←", "→", "↑" and / or "↓" key.









(3) Moving the focus from the keyboard

Use the "Alt" key to move the focus to the drop-down menu.

Use the "F6" key to move the focus between the project tree view and window (edit, monitor, trace, checking connect).





























(4) Shortcut key list

The following shortcut keys can be used with SW□D5C-QD75P-E.

Shortcut Key	Function (Corresponding Menu Item)	Tool Button	Shortcut Key	Function (Corresponding Menu Item)	Tool Button
Ctrl+N	New project file		Ctrl+Y	Clear row	—
Ctrl+O	Open project file		Ctrl+B	Select block start no	—
Ctrl+S	Save		Ctrl+T	Write to QD75	
Ctrl+G	Change QD75 model	—	Ctrl+M	Monitor On/Off	
Ctrl+P	Print		Ctrl+F4	Close active window	—
Ctrl+X	Cut		Ctrl+F6	Change active window	—
Ctrl+C	Copy		F1	Help	—
Ctrl+V	Paste		Alt+F4	Change active window	—
Ctrl+A	Select All	—		Exit/close dialog box	
Ctrl+J	Jump	—			

(5) Tool button list

The following table lists the tool buttons of SW□D5C-QD75P-E.

Toolbar Type	Tool Button	Function (Corresponding Menu Item)	Toolbar Type	Tool Button	Function (Corresponding Menu Item)
Toolbar		New project file	Test toolbar		Test On/Off
		Open project file			All axis stop command
		Save			Error reset #1
		Cut			Error reset #2
		Copy			Error reset #3
		Paste			Error reset #4
		Print			M code off #1
		Help (operation explanation)			M code off #2
Online toolbar		Read from QD75			M code off #3
		Write to QD75			M code off #4
		Verify QD75			Operation Test #1
		Monitor On/Off			Operation Test #2
		Check QD75 data			Operation Test #3
					Operation Test #4
					Positioning data edit in test mode
				Teaching	

6. PROJECT CREATION

A project is a collection of parameters, positioning data and block start data.

<SW□D5C-QD75P-E project makeup>

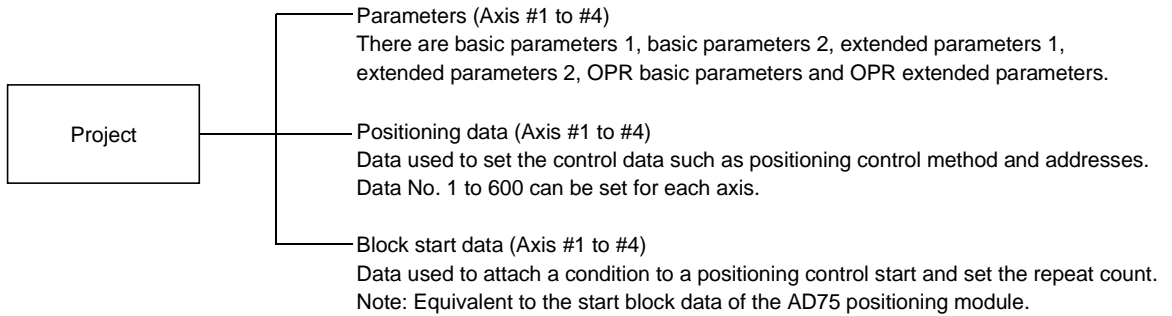

Point

- When executing "New Project" or "Save as Project", you cannot set a space and period in the project name to be specified. Further, you cannot set the following characters and symbols.

/ , : ; * " < > | \ \ COM LPT AUX CON PRN NUL CLOCK\$

- You cannot set the following characters and symbols in a project path.

/ , : ; * " < > | \ \ COM LPT AUX CON PRN NUL CLOCK\$

6.1 Creating a New Project

Set the QD75 model used to create a new project and the project items.

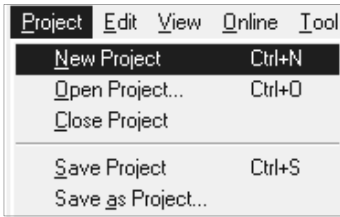

1) Click the [Project] → [New Project] menu ().

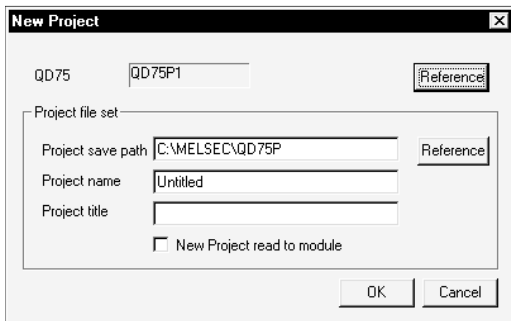

2) Click the "Reference" button of the QD75 type in the [New Project] dialog box.

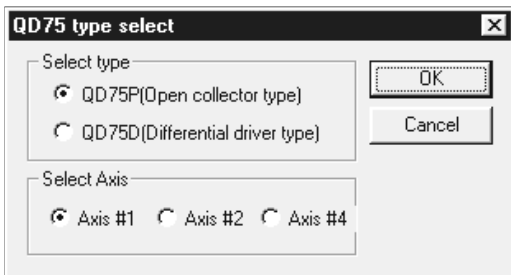

3) Choose the Select type and Select Axis radio buttons.
 4) Click the "OK" button.

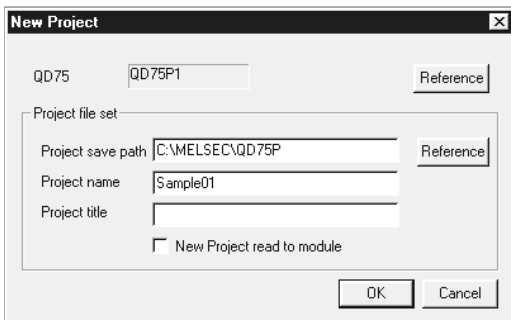

5) Set the project save path.
 The project save path defaults to C:\MELSEC\QD75P.
 When changing it, refer to "HELPFUL OPERATION (PART 1)" in this section.

6) Set the project name.
 When specifying the project file name, you can use a total of up to 150 characters to set the project path and project name.
 When setting the project path and project name, the total number of characters should be within 150.
 This screen assumes that the project name is "Sample01".

7) Set the project title as required.

8) Click the "OK" button.
 This creates a new project.

* To utilize the data read from the QD75, refer to "HELPFUL OPERATION (PART 2)" in this section.



HELPFUL OPERATION (PART 1)

You can perform the operation of changing the project save path while simultaneously checking the project tree.

In step 5) on the preceding page, click the Project file set "Reference" button. When the following dialog box appears, choose the project save path from the project tree or type it from the keyboard.

This operation is also used to perform such operations as "Open Project", "Save Project" and "Delete Project".

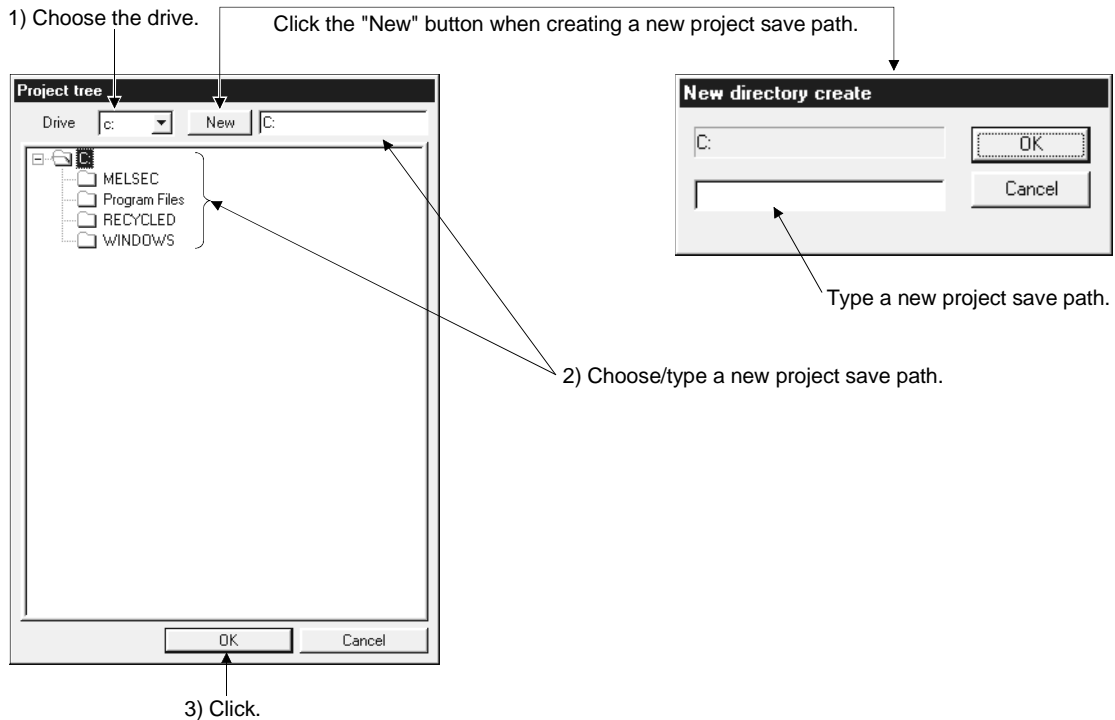

Point

- When saving a project, you cannot set "Untitled" in Project name. Also, do not use "Untitled n (n: 1, 2, 3)" in Project name. If you read "Untitled 1" and create a new project in default setting, the same project name (Untitled 1) appears on the Project tree view.



HELPFUL OPERATION (PART 2)

When utilizing the data written to the QD75 to create a new project, perform the following operation.

1. Set the QD75 type, project save path, project name and project title in the New Project dialog box.
2. Click the "New Project read from unit" check box.
3. Click the "OK" button.
4. Click the "OK" button in the instruction dialog box.
5. Set the interface, I/O address and others in the Connection setup dialog box (refer to Section 7.1).
6. Click the "OK" button.
7. Set the type and range of the data to be read in the QD75 Reading dialog box (refer to Section 9.1).
8. Click the "OK" button to read the positioning data, block start data and parameters in the specified range from the QD75.

<New QD75 reading procedure>

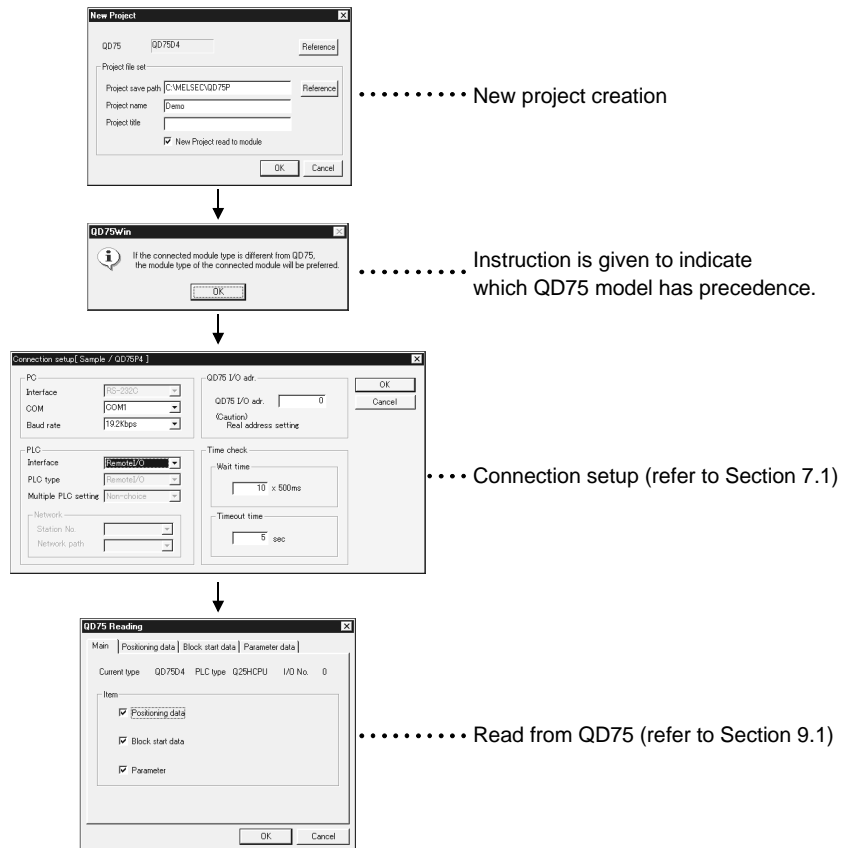

Point

- When new project read from unit is performed for new project creation, the QD75 connected has precedence if the QD75 model of the project differs from the QD75 model connected. After completion of reading, choose the [Project] → [Change QD75 model] menu to change the model. (Refer to Section 11.1.2.)

6.2 Opening the Existing Project

This section explains the operation of opening the saved project.

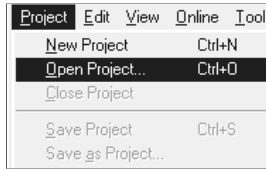

1) Click the [Project] → [Open Project] menu ().

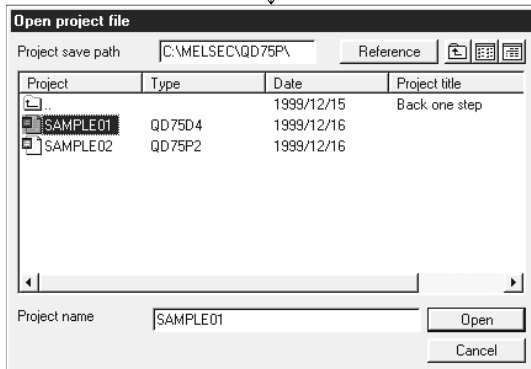

2) Click the project name.
For the setting operation of referring to the project save path, refer to "HELPFUL OPERATION (PART 1)" in Section 6.1.

3) Click the "Open" button.

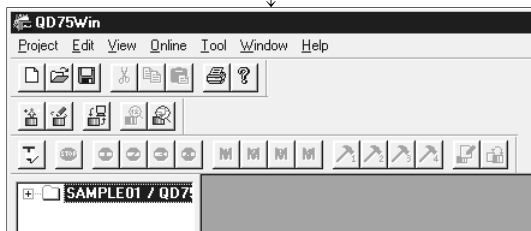

4) The specified project opens.

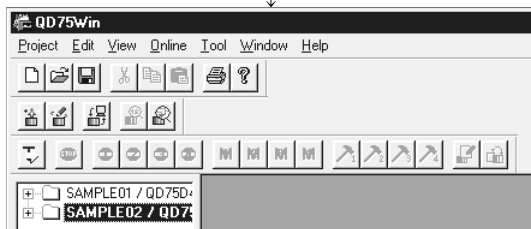

5) To open multiple projects, repeat the operations in steps 1) to 3).

The open projects are displayed on the project tree view.



- Recently opened projects (files) can be opened from the project menu
Up to four projects can be displayed.
Note that any projects not saved do not remain in the project menu.
In the initial setting, the [Latest file] menu item appears.

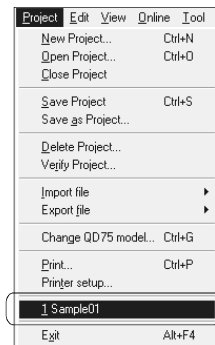

6.3 Saving the Project

**PURPOSE**

The project file which is currently edited is saved.

**BASIC OPERATION**

1. Set the project to be saved as the active project. (Refer to Section 5.2.)
2. To perform save operation, click the [Project]→[Save Project] menu ().
To perform save as operation, click the [Project] → [Save as Project] menu.
When specifying the project file name, you can use a total of up to 150 characters to set the project path and project name.
When setting the project path and project name, the total number of characters should be within 150.
For the operation of setting the project save path and project name, refer to "HELPFUL OPERATION (PART 1)" in Section 6.1.

**DISPLAY/SETTING SCREEN**
**HELPFUL OPERATION**

You cannot use "Save as Project" to overwrite the same project name. When you want to change the title in the same project name, perform the following operation.

1. Double-click "Project information" on the Project tree view.
2. Click the unchecked "Modified title " check box in the Project information window and change the current title.
3. Click the [Project] → [Save Project] menu.

Point

- When saving a project, you cannot set "Untitled" in Project name. Also, do not use "Untitled n (n: 1, 2, 3)" in Project name. If you read "Untitled 1" and create a new project in default setting, the same project name (Untitled 1) appears on the Project tree view.

6.4 Closing the Project

**PURPOSE**

The open project is closed.

**BASIC OPERATION**

1. Set the project to be closed on the project tree view.
2. Click the [Project] → [Close Project] menu.
3. If any setting has been changed, the dialog box appears to confirm whether the project will be saved or not.
Click the "Yes" button to save and close the project.
Click "No" to close the project without saving it.

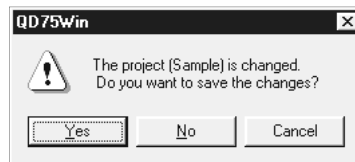
**DISPLAY/SETTING SCREEN**

6.5 Deleting the Project

**PURPOSE**

The project is deleted from HD, FD, etc..

**BASIC OPERATION**

1. Click the [Project] → [Delete Project] menu.
2. In the Delete project file dialog box, choose the project you want to delete and click the "Delete" button.
Refer to "HELPFUL OPERATION (PART 1)" in Section 6.1 for the operation of changing the project save path.
3. As the project file deletion confirmation dialog box appears, click the "Yes" button.
4. The project is deleted.

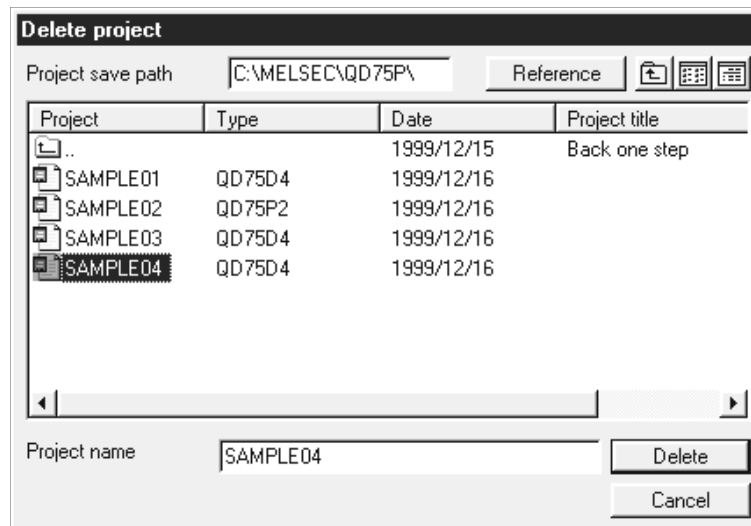
**DISPLAY/SETTING SCREEN**

6.6 Reading Other Format Files

6.6.1 Reading SW1IVD-AD75P-E format file

**PURPOSE**

The positioning data, M code comments, block start data, condition data and parameters are read from the file of the MELSEC-A series software package (SW1IVD-AD75P-E, SW0D5C-AD75P-E) as a new project of SW□D5C-QD75P-E.

**BASIC OPERATION**

1. Click the [Project] → [Import file] → [File reading of SW1IVD-AD75P]/[File reading of SW0D5C-AD75P] menu.
2. Choose the file in the Open dialog box and click the "Open" button.
3. Click the "OK" button in the read destination confirmation dialog box.
4. Set the QD75 model, project save path, project name and project title in the Other file type project dialog box. (Refer to Section 6.1 "HELPFUL OPERATION (PART 1)".)
5. Click the "OK" button.

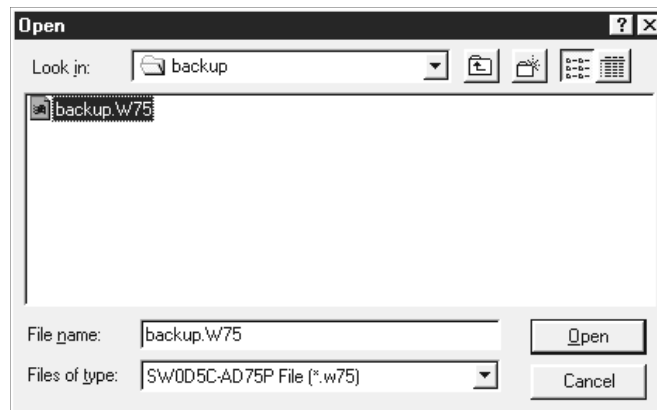
**DISPLAY/SETTING SCREEN**

(The screen shows an example of SW0D5C-AD75P file read.)

**DISPLAY/SETTING DATA**

Item	Description
Look in	Choose the project save path of the file you will read.
File name	Set the file name you will read.
Files of type	SW1IVD-AD75P-E File (*.d75) or SW0D5C-AD75P-E File (*.w75) appears.
"Up One Level" button	Click this button to show the folder one level above the currently displayed folder.
"List" button	Click this button to list files and folders.
"Details" button	Click this button to display the file and folder in detail.
"Open" button	Click this button to read the file.



- Since there are no four-axis type AD75 positioning modules, the positioning data, block start data and parameters of the fourth axis are not read if the QD75 model of the save destination project is of the four axis type.
- Note the following when the file in the SW1IVD-AD75P-E or SW0D5C-AD75P-E format has been read.

Data Type		Read to SW <input type="checkbox"/> D5C-QD75P-E	
Parameter	Start bias speed	Section is changed from basic parameter 2 to basic parameter 1	
	Output pulse logic selection	MPG	These are new items and therefore not read. Default setting.
		Over limit switch	
		Under limit switch	
		Drive unit ready	
		Stop signal	
		External signal	
		Zero phase signal	
		Zeroing dog	
		MPG	
	DCC	This name has been changed from the pulse output logic selection to the drive unit.	
	Command pls signal		
	Stepping motor mode selection	These are disused items and therefore read-disabled.	
	Manual pulse generator selection		
ACC/DEC time unit selection			
Near path control mode	These are disused items and therefore read-disabled. (Because near path control mode is fixed)		
MPG mode	This is a new item and therefore read-disabled. Default setting.		
Speed-position function selection			
Positioning data	SLV axis	This is a new item and therefore read-disabled. Default setting.	
	Positioning comment	Not read from SW1IVD-AD75P-E.	
Block start data	This name has been changed from the start block data. Because of reduction in number of blocks, block numbers 5 to 10 are read-disabled. "Stop" in special start is replaced by "Wait start".*		
Indirect Data	This is a disused item and therefore read-disabled.		

*: After file reading, condition data setting is needed.

6.6.2 Reading the CSV format file



PURPOSE

SW-D5C-QD75P-E allows CSV format files created with spreadsheet software, etc. be read as positioning data (axis #1 to #4). (Parameters and block start data cannot be read.)

The creating method and reading operation of CSV format data are described below.



- If all items that make up positioning data have not been entered, CSV format data cannot be read, resulting in an error.
- Since CSV format data is read axis-by-axis, create CSV format data noting which axis (#1/#2/#3/#4) data is being created.

(1) CSV format data creating method

The following sheet indicates the items and values of CSV format data set on a column basis.

<Example of data set to spreadsheet software>

	A	B	C	D	E	F	G	H	I	J
1	2 A		2	0	1	1000	0	500	0	1
2	2 F		2	0	1	1000	1000	500	0	2
3	2 A		2	0	1	-1000	0	500	0	3
4	2 F		2	0	1	-1000	-1000	500	0	0
5	0 A		2	0	1	0	0	500	0	0
6										
7										

1) 2) 3) 4) 5) 6) 7) 8) 9) 10) 11)

<Data set to the above spreadsheet software was read with SW-D5C-QD75P-E>

No.	Pattern	CTRL method	SLV axis	ACC(ms)	DEC(ms)	Positioning address [pls]	Arc Address [pls]	Command speed [pls/sec]	Dwell time [ms]	M code
1	2:LOCUS A:ABS line2		Axis #2	0:1000	0:1000	1000	0	500	0	1
2	2:LOCUS F:ABS ArcRGT		Axis #2	0:1000	0:1000	1000	1000	500	0	2
3	2:LOCUS A:ABS line2		Axis #2	0:1000	0:1000	-1000	0	500	0	3
4	2:LOCUS F:ABS ArcRGT		Axis #2	0:1000	0:1000	-1000	-1000	500	0	0
5	2:LOCUS A:ABS line2		Axis #2	0:1000	0:1000	0	0	500	0	0
6	2:LOCUS									

Number	Setting	Remarks
1)	Set the positioning control pattern in column 1 from left. Set any value from 0 to 2.	Refer to Section 8.2 for details of data corresponding to alphanumeric values to be set.
2)	Set the operation method in column 2 from left. Set it with 1 to 9 and A to Z.	
3)	Set the interpolation axis for two-axis interpolation control in column 3 from left.	
4)	Set the host axis for single-axis or three-/four-axis interpolation control.	
5)	Set the accel time No. in column 4 from left. Set it from 0 to 3.	
6)	Set the decel time No. in column 5 from left. Set it from 0 to 3.	
7)	Set the address in column 6 from left.	
8)	Set the circular positioning address in column 7 from left.	
9)	Set the command speed in column 8 from left.	
10)	Set the dwell time in column 9 from left.	
11)	Set the M code in column 10 from left.	

(2) CSV format file reading operation

 **BASIC OPERATION**

1. On the project tree view ,set the active project whose CSV format file will be read. (Refer to Section 5.2.)
2. Click the [Project] → [Import file] → [File reading of CSV form positioning data] menu.
3. Click the "Yes" button in the dialog box which confirms that the read CSV format data will replace the present positioning data.
4. Choose the axis in the Object axis selection dialog box and click the "OK" button.
5. Choose the file and file type in the Open dialog box and click the "Open" button.
6. Click the "OK" button in the read confirmation dialog box.

 **DISPLAY/SETTING SCREEN**

[Object axis selection dialog box]

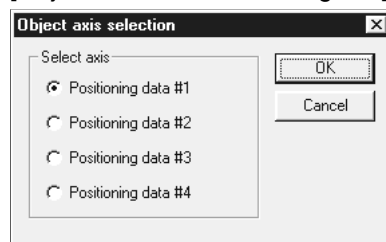

[Open dialog box]

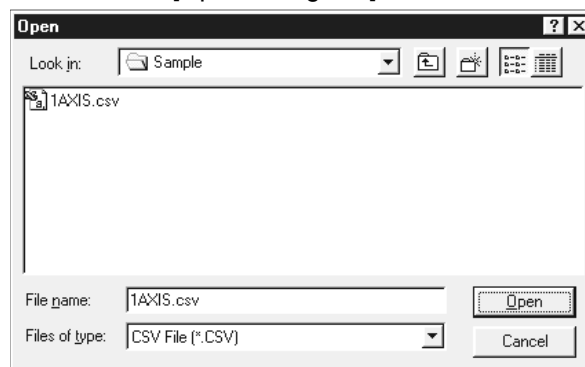

 **DISPLAY/SETTING DATA**

Item	Description
Object axis selection dialog box	Choose the axis whose positioning data will be saved in the CSV format.
Look in	Choose the project save path of the file you will read.
File name	Set the file name to be read to the project.
Files of type	CSV File (*.CSV) appears.
"Up One Level" button	Click this button to show the folder one level above the currently displayed folder.
"List" button	Click this button to list files and folders.
"Details" button	Click this button to display the file and folder in detail.
"Open" button	Click this button to read the file.

6.7 Write to CSV Format File

**PURPOSE**

The positioning data set in the project of SW□D5C-QD75P-E is saved in the CSV format file.

Refer to Section 6.6.2 (1) for the positioning data setting items and CSV format data.

**BASIC OPERATION**

1. On the project tree view , set as the active project the project whose positioning data will be saved in the CSV format file. (Refer to Section 5.2.)
2. Click the [Project] → [Export file] → [File writing of CSV form positioning data] menu.
3. Choose the axis in the Object axis selection dialog box and click the "OK" button.
4. Set the save location and file name in the Save As dialog box and click the "Save" button.
5. Click the "OK" button in the write confirmation dialog box.

**DISPLAY/SETTING SCREEN**

[Object axis selection dialog box]

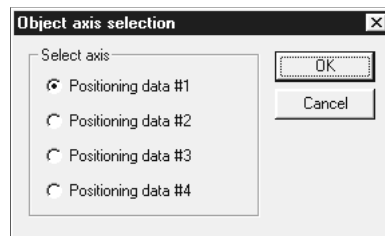

[Save As dialog box]

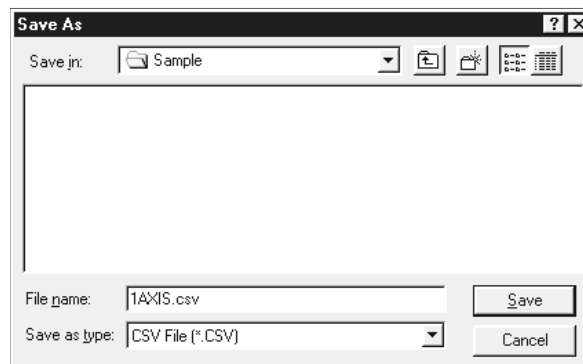

*DISPLAY/SETTING DATA*

Item	Description
Object axis selection dialog box	Choose the axis whose positioning data will be saved in the CSV format.
Save in	Choose the drive or folder where the data will be saved.
File name	Set the file name to be saved in the other format file.
Files of type	CSV File (*.CSV) appears.
"Up One Level" button	Click this button to show the folder one level above the currently displayed folder.
"Create New Folder" button	Click this button to create a "new folder".
"List" button	Click this button to list files and folders.
"Details" button	Click this button to display the file and folder in detail.
"Save" button	Click this button to save the other format file.

7. SYSTEM CHECKING FROM PERIPHERAL DEVICE

Specify the QD75 to be accessed per project, also check connections with the external equipment (servo amplifiers, servo motors, etc.), and conduct initial operation tests of the servo motors.

7.1 Connection Setup



PURPOSE

Choose the interface connected to the QCPU or Q corresponding serial communication module, and set the I/O address, etc. of the QD75 to be accessed.



BASIC OPERATION

1. Click the [Online] → [Connection setup] menu.
2. Choose the interface in the Connection setup dialog box and set the I/O address, etc.
3. After the setting is completed, click the "OK" button.



DISPLAY/SETTING SCREEN

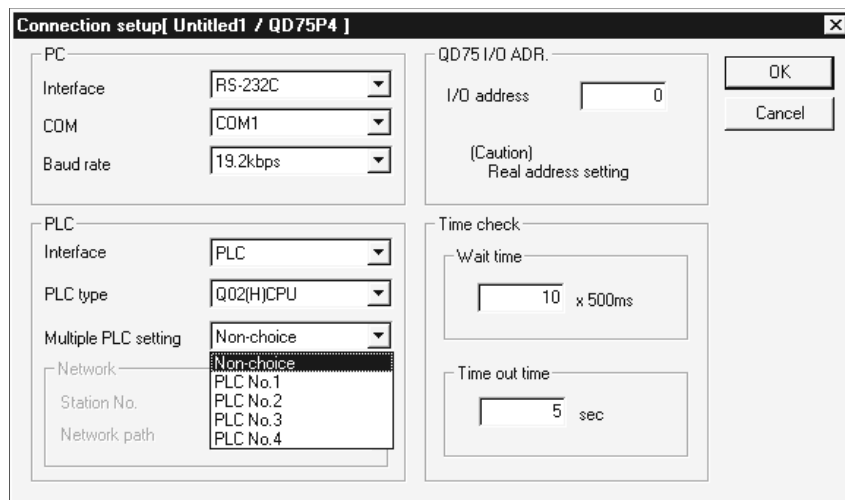

DISPLAY/SETTING DATA

Item	Description
(Personal computer side) Interface	Choose the type of the personal computer side interface. The selection range is RS232C or USB. (This is fixed to RS-232C if C24 connection or remote I/O was selected as the PLC side interface.)
COM	Choose the COM port if the personal computer side interface is RS-232C. The selection range is COM1 to COM10.
Baud rate	Choose the baud rate if the personal computer side interface is RS-232C. The selection range is 9.6kbps to 115.2kbps.

Item	Description
(PLC side) Interface	Choose the type of the PLC to be connected. Choose the CPU module, C24 connection, remote I/O or ladder logic test.
PLC type	When the CPU module was selected as the PLC side interface, choose the type of the control PLC of the QD75 to communicate with.
Multiple PLC setting	When the CPU module was selected as the PLC side interface, choose the PLC No. of the control PLC of the QD75 to communicate with in a multiple PLC system configuration. The selection range is Non-choice, PLC No. 1, PLC No. 2, PLC No. 3 and PLC No. 4. For a single PLC system configuration, choose "Non-choice".
Network	Not supported by this software package.
I/O address	Set the I/O address (starting I/O number) of the QD75 to be accessed in hexadecimal.
Wait time	Set the time-out period until the QD75 accepts a start or similar request from SW□D5C-QD75P. When time-out occurs, the operating axes all stop.
Timeout time	Set the suspension time of communication judged as a communication error.



- If you set the personal computer interfaces to the same COM port in SW□D5C-QD75P-E and SW□D5C-GPPW-E, set the baudrate to the same speed.
If they are started at the same time, the baudrate set first has priority and the baudrate set later is ignored.
- If SW□D5C-QD75P-E is forced to end in the test mode, a time-out occurs due to the elapse of the wait time and the QD75 cancels the test mode.
- A communications error may occur if communications are made with the QCPU after setting of any of the resume function, suspend setting, power-saving function and standby mode of the peripheral device. For this reason, do not set the above functions when communicating with the QD75.
- If the USB cable is disconnected/connected, the QCPU is reset, or power is switched on/off frequently during communications with the QCPU, a communications error may occur and the QD75 may not recover from the error.
Hence, place the QD75 offline when disconnecting/connecting the USB cable, resetting the QCPU, or switching power on/off.
If the QD75 does not recover from the communications error, completely disconnect the USB cable once and reconnect it after more than 5 seconds has elapsed. (An error may occur at the initial communications after this operation, but the QD75 will function properly from the second time onwards.)
- A communication error may occur depending on the combination of the personal computer model, USB cable and so on.
In that case, refer to the message displayed and perform operation again.
- If the baudrate is changed at the serial port of the personal computer (personal computer interface) to perform fast communication, communications may not be made or a communications delay may occur due to a communications retry depending on the performance of the personal computer.
If communications cannot be made for fast communication, reduce the baudrate and restart communication.

REMARK

When the PLC interface is C24 connection (Q corresponding serial communication module), the Q corresponding serial communication module switches must be set on the PLC parameter I/O assignment setting screen of GPPW.

Refer to GPPW Operating Manual (function version of "4" or later), for the way to make settings in the I/O assignment setting screen.

For more information on the switch settings, refer to "Q Corresponding Serial Communication Module User's Manual (Basic Manual)".

Switch setting examples are listed below.

Item	Description		Setting
Switch 1	CH1 communication speed	CH1 transmission setting	0726H
Switch 2	-	CH1 communications protocol	0008H
Switch 3	CH2 communication speed	CH2 transmission setting	0727H
Switch 4	-	CH2 communications protocol	0000H
Switch 5	Module station number		0000H

Detailed description of settings

Item	Setting
Operation setting	Independent setting
Data bit setting	8
Parity bit yes/no setting	Yes
Odd/even parity bit	Odd
Stop bit setting	1
Sum check yes/no setting	Yes
Online change enable/disable setting	Enable
Setting change enable/disable setting	Disable
Transmission speed setting	19200bps
Communications protocol	GPPW link

7.2 System Monitor



PURPOSE

Check the module configuration, I/O address, QD75 model and axis statuses of the station (system) connected.



BASIC OPERATION

1. Set the connection target. (Refer to Section 7.1.)
2. Click the [Tool] → [System monitor] menu.
3. The QD75 on the connected station appears in the System monitor dialog box.
4. Click the QD75 illustration and check the I/O address, model and axis statuses.
5. To exit, click the "Close" button.



DISPLAY/SETTING SCREEN

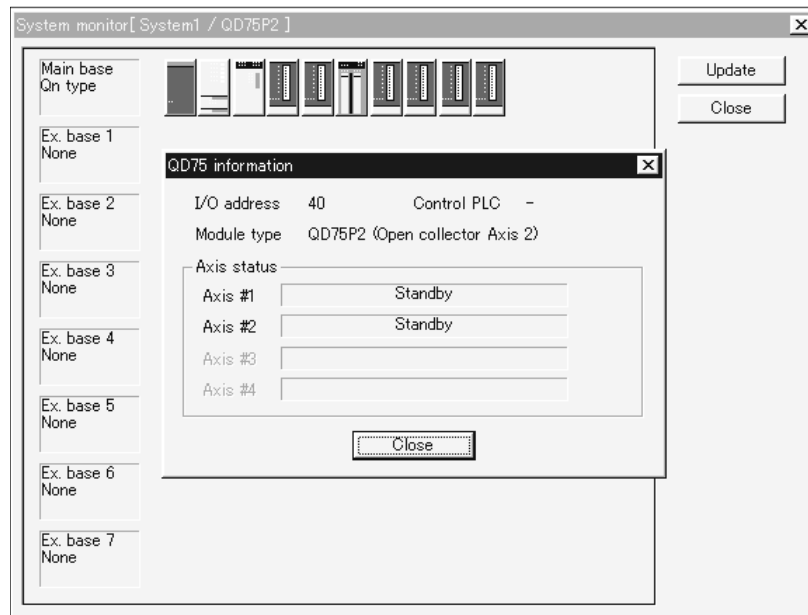

DISPLAY/SETTING DATA

Item	Description
System monitor	Shows the connection target PLC system. Clicking the QD75 illustration shows the QD75 module information.
QD75 Information	Shows the I/O address, module type and module axis statuses.
"Update" button	Click this button to show the latest system information.

7.3 Checking the QD75 Function Version (OS Information)



PURPOSE

Depending on the function version of the QD75, this software may not be compatible with some functions.(Refer to Section 1.3)
 Before setting various data, check the function version (product information) of the QD75 with the setting software.



BASIC OPERATION

1. Specify the connection target. (Refer to Section 7.1.)
2. Click the [Online] → [OS information] menu.
3. Check the function version in the OS information dialog box.
4. To exit, click the "Close" button.



DISPLAY/SETTING SCREEN

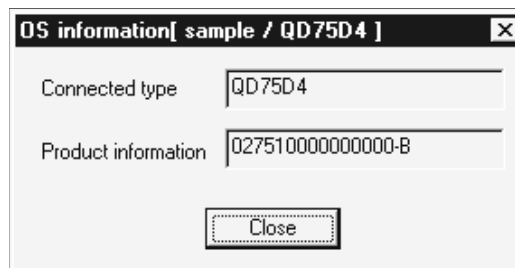

DISPLAY/SETTING DATA

Item	DISPLAY/SETTING SCREEN
Connected type	Indicates the model of the connected QD75.
Product information	Indicates the function version of the connected QD75. The function version "B" is displayed on the above display/setting screen.

7.4 Checking Connect



**PURPOSE**

Make sure that the cables between QD75 and servo amplifiers and between servo motors, servo amplifiers and external devices are connected properly.

**BASIC OPERATION**

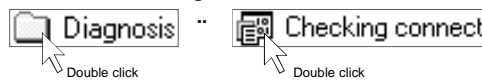
1. Power on the positioning system and STOP the PLC CPU.
2. Set the connection target. (Refer to Section 7.1.)
3. Choose Checking connect.



4. Click the "Online" button in the Checking connect window.
5. The online processing (test mode shift) confirmation dialog box appears.
Click the "Initialize" button to check connection after initializing the QD75.
Click "OK" to check connection without initializing the QD75.
6. Make sure that the external I/O signals are in the following states.
Drive unit ready, Upper limit, Lower limit: ON (red)
Stop signal: OFF (gray)
If any of the above states is not established, refer to "HELPFUL OPERATION (1)" and "HELPFUL CORRECTIVE ACTIONS" in this section.
7. Check whether the following signals from the external devices are ON or OFF.
Stop signal, External command.
8. Set the JOG speed.
9. Press the "FWD" or "REV" button to start JOG operation.
Hold down the button to continue JOG operation.
10. Perform JOG operation and check the operation, rotation direction and feed speed of the servo motor.
11. Perform JOG operation and check whether Zero phase and DOG signals turn on or off.
12. Perform JOG operation and check whether the upper and lower limit switches turn on or off.
Refer to "HELPFUL OPERATION (2)" in this section for the way to restore an axis stop due to OFF of the upper/lower limit switch.
13. When an error has occurred, check the error code definition with the help function (refer to Section 11.10), then click [Online] → [Test] → [Error Reset] → [Error Reset #1 to #4] menu ( to ).
14. To exit, click the "Offline" button, and click the "OK" button in the test mode end confirmation dialog box.

 DISPLAY/SETTING SCREEN

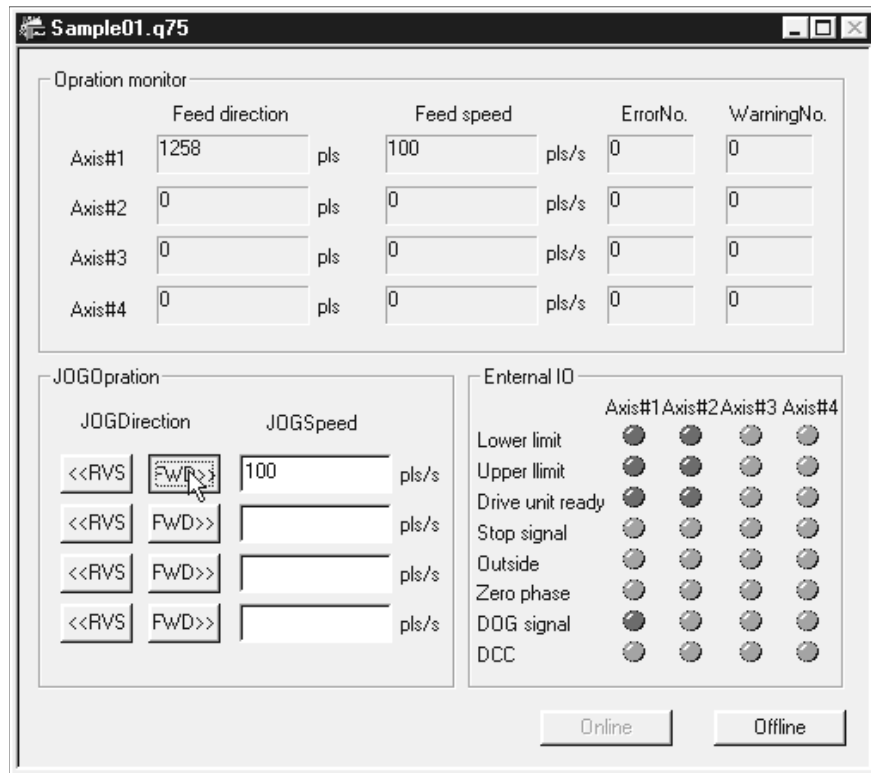

 DISPLAY/SETTING DATA

Item	Description
Operation monitor	Indicates the feed present value, feed speed, error No. and warning No. of each axis.
JOG speed	Set the speed for JOG operation.
JOG direction	Press the "FWD" or "RVS" button of the axis for JOG operation to start JOG operation.
External I/O	Indicates the external I/O signal states (ON: Red, OFF: Gray) of the QD75.
"Offline" button	Click this button to end the QD75 test mode and end Checking connect.
"Online" button	Click this button to start the QD75 test mode and execute Checking connect.



HELPFUL OPERATION (1)



Perform the following operation if the I/O logic states of the drive unit ready, upper/lower limit switch and stop signal are different from the initial settings (negative logic).

1. In the extended parameters, set the logic signals in which the following states are established during normal operation. (Refer to Section 8.1.)
 Drive unit ready, upper limit, lower limit: ON
 Stop signal: OFF
2. Write the parameters to the QD75. (Refer to Section 9.1.)
3. Perform steps 1 to 5 in the basic operation of this section.
4. Click the "No" button in the QD75 initialization confirmation dialog box.
5. The operation steps to be performed hereafter are the same as steps 7 to 14 in the basic operation of this section.



HELPFUL OPERATION (2)

Perform the following operation to restart the axis which was brought to an alarm stop as the upper/lower limit switch had turned OFF during JOG operation.

1. Click [Online] → [Test] → [Error Reset] → [Error Reset #1 to #4] menu ( to ).
2. Perform JOG operation to move the axis to within the upper or lower limit range.



HELPFUL CORRECTIVE ACTIONS

Take the following basic corrective actions when Checking connect cannot be completed properly.

Status	Corrective Action
Checking connect cannot start	Check the connection of cables with the QD75.
	In Connection setup, check whether the interface, CPU type and other settings are correct. (Refer to Section 7.1.)
Drive unit ready signal is OFF	Check that the servo amplifier is powered on.
	Check the connection of the external I/O signal connector.
	Change the extended parameter I/O logic.
Upper/lower limit signal is OFF	Check the connection of the external I/O signal connector.
	Check for contact of the upper/lower limit switch.
	Change the extended parameter I/O logic.
Stop signal is ON	Check the connection of the external I/O signal connector.
	Check the status of the stop switch.
	Change the extended parameter I/O logic.
JOG operation cannot be performed.	Check that JOG speed setting is not "0".
Error/warning occurred	Check the error/warning code using the help function, and remove the cause.

8. DATA SETTING

Set the parameters, positioning data and block start data to be written to the QD75, and check the setting ranges and matching of the data using the simulation or error check function.

Write the preset parameters, positioning data and block start data to the QD75 before starting positioning operation.

Refer to Section 9.1 for the operation to write the data to the QD75.

8.1 Parameter Setting

Set the parameters necessary to exercise positioning control.
For the setting data, refer to the QD75 user's manual.



PURPOSE

There are the following four parameter types.

- Basic parameters
- Extended parameters
- OPR basic parameters
- OPR extended parameters

The basic and extended parameters are divided into parameters 1 needed for system start and parameters 2 optimized according to the connected external devices and control.



BASIC OPERATION

1. Choose Parameter.



2. Make setting in the parameter edit window.



DISPLAY/SETTING SCREEN

Kind	Item	Axis #1	Axis #2
Basic Parameter 1	Unit	3:pulse	3:pulse
	Pulse per revolution	20000 pls	20000 pls
	Travel per revolution	20000 pls	20000 pls
	Unit multiplier	1: 1 times	1: 1 times
	Pulse output mode	1: CW/CCW mode	1: CW/CCW mode
	Rotation direction	0: Forward pulses to increase address	0: Forward pulses to increase address
	Start bias speed	0 pls/s	0 pls/s
Basic Parameter 2	Speed limit	200000 pls/s	200000 pls/s
	ACC time #0	1000 ms	1000 ms
	DEC time #0	1000 ms	1000 ms

Double-click the cell and make setting in the text box or list box.

In the text box, you can set the maximum value/minimum value/default value with the right-click menu.

When performing operation from the keyboard, enter the value and press the "Enter" key to determine the value.

In the list box which shows the set value and set data (example 3:pulse), pressing the "space" key displays a list.

Make selection with the "↑" or "↓" key, and press the "Enter" key to determine the value.

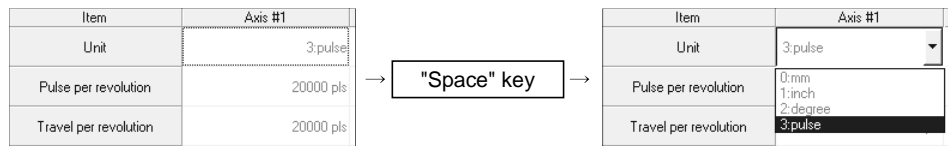

Point

- In the parameter edit window, the indications have the following meanings.
 - Blue characters : Default (initial value) setting
 - Black characters : Setting other than default (no error)
 - Red : Setting range error
- Since changing the unit setting changes the setting range, any setting other than the default (black characters) may result in a setting range error.
 - After changing the unit setting, make an error check to confirm the setting.

8.2 Positioning Data Setting

This section describes the positioning data setting, the addition of circular interpolation control to the positioning data by specifying a sub point, and speed setting using the axis speed calculation function.

This section also explains the M code comment setting in which the M codes assigned to the positioning data are annotated with comments.

8.2.1 Positioning data



PURPOSE

Set the positioning data such as the operation pattern, control method, SLV axis, acceleration time No., deceleration time No., address and command speed. For details of the positioning data, refer to QD75 User's Manual.



BASIC OPERATION

1. Choose the axis to which the positioning data will be set.



2. Set the data in the positioning data edit window.



DISPLAY/SETTING SCREEN

No.	Pattern	CTRL method	SLV axis	ACC(ms)	DEC(ms)	Positioning address [pls]	Arc Address [pls]
1	2:LOCUS	A:ABS line2	Axis #2	0;1000	0;1000	964	0
2	2:LOCUS	D:ABS ArcMP	Axis #2	3;1500	3;1500	964	979
3	0:END	A:ABS line2	Axis #2	0;1000	0;1000	0	0
4							
5							
6							
7							
8							
9							
10							
11	1:CONT	1:ABS line1	-	2;1200	3;1500	2000	0
12	1:CONT	1:ABS line1	-	2;1200	3;1500	3000	0
13	0:END	1:ABS line1	-	2;1200	3;1500	0	0
14							

Double-click the cell and make setting in the text box or list box. For "SLV axis", choose it from the SLV axis set dialog box when the control method is 2-axis interpolation control.



When performing operation from the keyboard, enter the value and press the "Enter" key to determine the value.

For "Pattern", "CTRL method", "ACC" and "DEC", press the "space" key to display a list.

Make selection with the "↑" or "↓" key, and press the "Enter" key to determine the value.



DISPLAY/SETTING DATA

Item	Description
No.	<p>Indicates the No. of the positioning data.</p> <p>The positioning data that can be ranges from No. 1 to 600.</p> <p>However, No. 1 to 100 are displayed in the initial setting.</p> <p>To change the display range, use the option function (refer to Section 11.5).</p>
Pattern	<p>Choose the operation pattern for positioning control.</p> <p>The selection range is 0 to 2.</p> <p>0: END (End command) 2: LOCUS (continue locus positioning control)</p> <p>1: CONT (continue positioning control)</p>
CTRL method	<p>Choose the operation positioning control method from among 1 to 9 and A to Z.</p> <p>1: ABS line 1 (Axis #1 Line interpolation (ABS))</p> <p>2: INC line 1 (Axis #1 Line interpolation (INC))</p> <p>3: Feed 1 (Axis #1 Fixed distance feed control)</p> <p>4: FWD velocity 1 (Axis #1 Velocity control (Forward))</p> <p>5: RVS velocity 1 (Axis #1 Velocity control (Reverse))</p> <p>6: FWD V/P (Velocity/Positioning change control (Forward))</p> <p>7: RVS V/P (Velocity/Positioning change control (Reverse))</p> <p>8: FWD P/V (Positioning/Velocity change control (Forward))</p> <p>9: RVS P/V (Positioning/Velocity change control (Reverse))</p> <p>A: ABS line 2 (Axis #2 Line interpolation (ABS))</p> <p>B: INC line 2 (Axis #2 Line interpolation (INC))</p> <p>C: Feed 2 (Axis #2 Fixed distance feed control)</p> <p>D: ABS ArcMP (Sub point setting arc interpolation control (ABS))</p> <p>E: INC ArcMP (Sub point setting arc interpolation control (INC))</p> <p>F: ABS ArcRGT (Center point setting arc interpolation control (ABS/CW))</p> <p>G: ABS ArcLFT (Center point setting arc interpolation control (ABS/CCW))</p> <p>H: INC ArcRGT (Center point setting arc interpolation control (INC/CW))</p> <p>I: INC ArcLFT (Center point setting arc interpolation control (INC/CCW))</p> <p>J: FWD velocity 2 (Axis #2 Velocity control (Forward))</p> <p>K: RVS velocity 2 (Axis #2 Velocity control (Reverse))</p> <p>L: ABS line 3 (Axis #3 Line interpolation (ABS))</p> <p>M: INC line 3 (Axis #3 Line interpolation (INC))</p> <p>N: Feed 3 (Axis #3 Fixed distance feed control)</p> <p>O: FWD velocity 3 (Axis #3 Velocity control (Forward))</p> <p>P: RVS velocity 3 (Axis #3 Velocity control (Reverse))</p> <p>Q: ABS line 4 (Axis #4 Line interpolation (ABS))</p> <p>R: INC line 4 (Axis #4 Line interpolation (INC))</p> <p>S: Feed 4 (Axis #4 Fixed distance feed control)</p> <p>T: FWD velocity 4 (Axis #4 Velocity control (Forward))</p> <p>U: RVS velocity 4 (Axis #4 Velocity control (Reverse))</p> <p>V: NOP (NOP command)</p> <p>W: Address CHG (Address change)</p> <p>X: JUMP (JUMP command)</p> <p>Y: LOOP (Start loop point)</p> <p>Z: LEND (End loop point)</p>

Item	Description
SLV axis	Set the interpolation axis when the control method is linear interpolation control (2 axes) or circular interpolation control. Use the SLV axis set dialog box.
ACC DEC	Choose the ACC time or DEC time from among 0 to 3 and set in the basic parameters 2 and extended parameters 2.
Positioning address	Set the address for the absolute system or the travel distance for the incremental system. Set a new current value when the control method is an address change.
Arc Address	Set the address of the sub point or center point designated for circular interpolation control.
Command speed	Set the command speed for positioning. Set the command speed to "-1" to exercise control at the current speed.
Dwell time	<ul style="list-style-type: none"> Control method is other than "JUMP" Set the delay time till the next positioning data completion in the range 0 to 65535ms. Control method is "JUMP" Set any position from No. 1 to 600 of the JUMP destination.
M code	<ul style="list-style-type: none"> Control method is other than "JUMP" or "LOOP" Set the M code used to perform work, process, etc. in synchronization with positioning control in the range 1 to 65535. Control method is "JUMP" Set any of the condition data No. 1 to 10 which is used as the JUMP command execution condition. Setting of the condition data whose condition operator is "Simultaneously start axis set" is invalid. Set "0" to execute the JUMP command unconditionally. Control method is "LOOP" Set the repeat count within the range 1 to 65535.
Positioning comment	Assign a comment per positioning data. You can set a comment of up to 32 characters.



- The colors of the cells (list) in the positioning data edit window have the following meanings.
 - Yellow : Setting must not be made since the data is on the interpolation axis side of interpolation control.
 - Red : Item needing setting is not yet set or is in error.
 - Gray : Setting need not be made (setting value is invalid).1)



HELPFUL OPERATION (1)

When you want to use a smooth arc (curve) on an intersection of two consecutive linear interpolation controls, you can perform the following operation to insert the circular interpolation control positioning data between the linear interpolation controls.

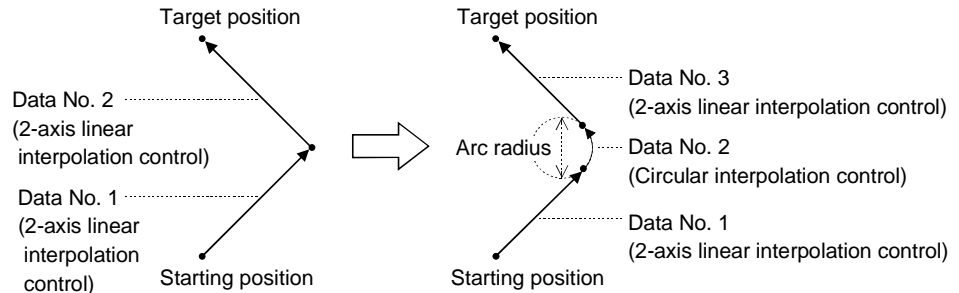

1. Open the positioning data edit window of the reference axis to which sub arc setting will be made.
2. Click the [Edit] → [Sub arc] menu.
3. Set "Data" and "SubArc Radius" in the SubArc Setting dialog box.
4. Click the " Calculation " button.
5. The positioning data overwrite confirmation dialog box appears. Click the "OK" button.

<Sub arc setting example>

No.	Pattern	CTRL method	SLV axis	ACC(ms)	DEC(ms)	Positioning address [pls]	Arc Add
1	2LOCUS A:ABS line2		Axis #2	0,1000	0,1000	-1000	
2	2LOCUS A:ABS line2		Axis #2	0,1000	0,1000	0	
3	0.END A:ABS line2		Axis #2	0,1000	0,1000	-1000	



SubArc Setting							
Data No	2		SubArc Radius	50 [pls]		Calculation Cancel	
No.	Pattern	CTRL method	SLV axis	ACC(ms)	DEC(ms)	Positioning address [pls]	Posit address [p]
2	2LOCUS A:ABS Line2		Axis #2	0,1000	0,1000	0	
3	0.END A:ABS Line2		Axis #2	0,1000	0,1000	-1000	



Sample1 / QD75D4 / Positioning data Axis #1 (I/O : 0)							
No.	Pattern	CTRL method	SLV axis	ACC(ms)	DEC(ms)	Positioning address [pls]	Arc Add
1	2LOCUS A:ABS line2		Axis #2	0,1000	0,1000	-1000	
2	2LOCUS A:ABS line2		Axis #2	0,1000	0,1000	-35	
3	2LOCUS D:ABS ArcMP		Axis #2	0,1000	0,1000	-35	
4	0.END A:ABS line2		Axis #2	0,1000	0,1000	-1000	

- Open the positioning data edit window of axis 1 which is used as the reference axis.
- Click the [Edit] → [Sub arc] menu.
- Set "1" to "Data" and "50" to "SubArc Radius".
- Click "OK" in the positioning data overwrite dialog box.
- The address of data No. 1 is changed and data No. 2 changes to circular interpolation control data. The original data of data No. 2 is set to data No. 3.



- Since the selected No. and next No. are overwritten by the positioning data created in sub arc setting, leave the next No. as NOP (empty).
- In either of the following cases, you cannot make sub arc setting.
The control method is other than 2-axis linear interpolation control or fixed-distance feed 2.
Positioning data setting is in error.



HELPFUL OPERATION (2)

Perform the following operation when you want to determine the command speed from the time needed to complete positioning. Use the axis speed calculation function to calculate the command speed from the travel distance, acceleration time, deceleration time, time needed for positioning completion and so on.

1. Open the positioning data edit window of the corresponding axis. (Active status)
2. Click the [Edit] → [Speed of axis setting] menu.
3. Set the Rating, Feedback, Start position, End position, Operation interval and Data No. in the Axis speed calculation dialog box, and choose ACC interval and DEC interval.
4. Click the "Calculation" button to show the operation result in the Confirmation dialog box.
5. Click "OK" in the Confirmation dialog box to change the command speed to that of the operation result.

[Axis speed calculation dialog box]

[Confirmation dialog box]

No.	Pattern	CTRL method	ACC[ms]	DEC[ms]	Position address
1	0:END	1:ABS Line1	0,1000	0,1000	51

Point

- Axis speed calculation is to be made for the control method of 1-axis linear control (ABS).
- If the axis speed calculated exceeds the speed limit value, setting it to the positioning data will result in an error.
- You cannot perform axis speed calculation if the set number of pulses output exceeds the performance of the QD75.
 - For QD75P1/P2/P4 (open collector output type)
 $\text{Number of output pulses ((rated speed) } \times \text{ (number of feedback pulses) / 60)} \leq 200\text{kpps}$
 - For QD75D1/D2/D4 (differential driver output type)
 $\text{Number of output pulses ((rated speed) } \times \text{ (number of feedback pulses) / 60)} \leq 1\text{Mpps}$

8.2.2 M code comment



PURPOSE

Set comments to M codes which are required for control exercised in synchronization with positioning control.
 M code comments are data which can be saved only in the personal computer.
 Up to 50 comments can be set for each axis.



BASIC OPERATION

1. Choose the positioning data of the axis to which the M code comments will be set.



2. Click the [Edit] → [M code comment] menu.
3. Set the M code comments.
4. To exit, click the "OK" button in the M code comment dialog box.



DISPLAY/SETTING SCREEN

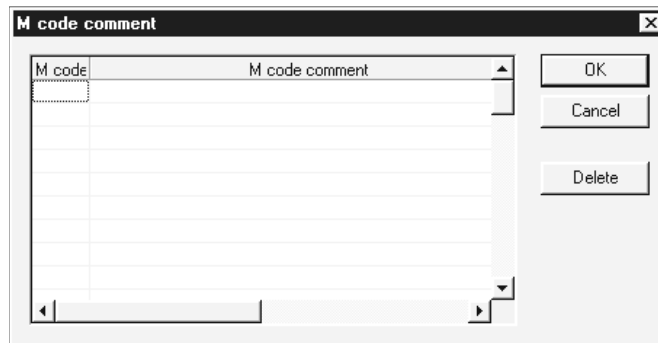

DISPLAY/SETTING DATA

Item	Description
M code	Set the M code No. to be commented.
M code comment	Set a comment of up to 32 characters. Up to 50 comments can be set for each axis.
"OK" button	Click this button to finish the setting.
"Delete" button	Click this button to delete the selected comment.

8.3 Simulation

**PURPOSE**

Execute simulation (virtual positioning) with the set positioning data to check the operation of the axis.

The axis speed is displayed as locus data for 1-axis control or as locus data for 2-axis interpolation control.

You cannot perform simulation for 3-/4-axis interpolation control.

**BASIC OPERATION**

1. Open the positioning data edit window.



2. Click the [Edit] → [Simulation] menu.
3. Type the first No. of positioning data in the simulation window.
4. Setting or changing the positioning data being simulated in the positioning data edit window shows the simulation result at the point of data input.
5. To exit, click the "CLOSE" button.

**DISPLAY/SETTING SCREEN**

[Locus data for 1-axis control]

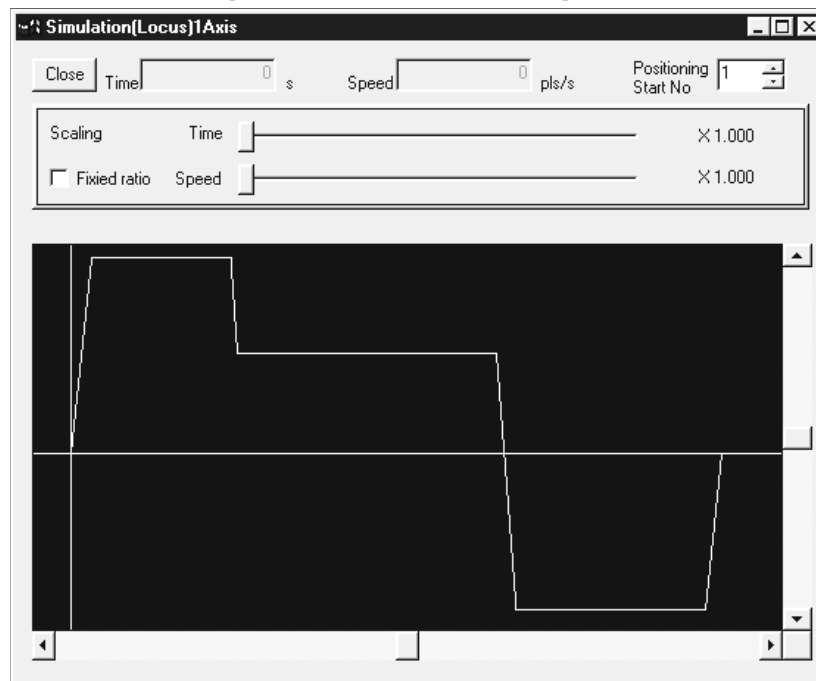

[Locus data for 2-axis interpolation control]

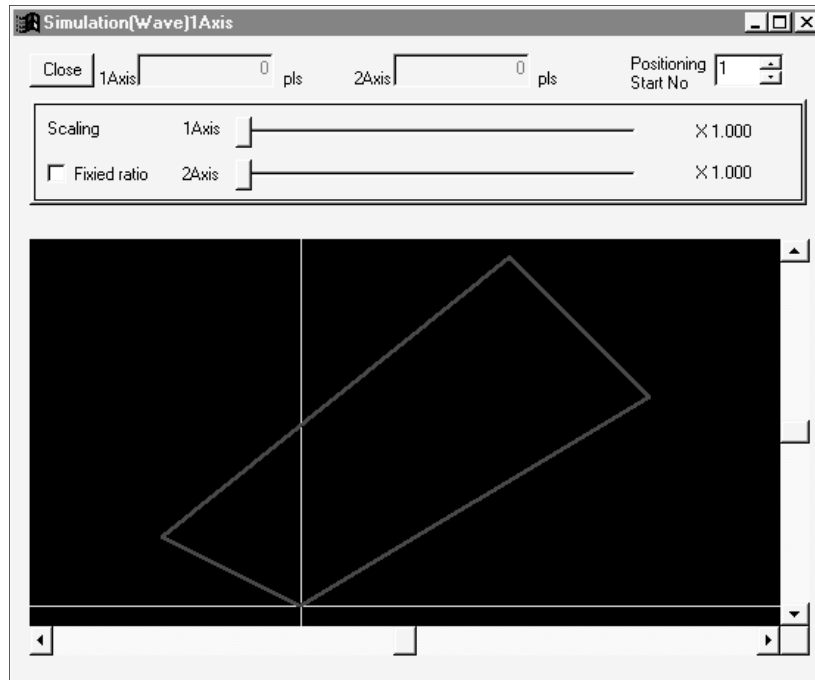

DISPLAY/SETTING DATA

Item	Description
Positioning start No.	Set the first positioning data No. from which simulation starts. Simulation is performed on the data from the specified No. to the "End" of the operation pattern.
Scaling	Used to enlarge or reduce the simulation result in the vertical and horizontal directions. Moving the side to the right enlarges the result.
"Fixed ratio" check box	Click the unchecked check box to enlarge/reduce the result in the vertical and horizontal directions by the same ratio.
Time/Speed (Waveform data)	Shows the time and axis speed at the position clicked in the simulation result display.
#1 to #4 axis coordinates (Locus data)	Shows the coordinates at the position clicked in the simulation result display. In the screen example, the coordinates shown are those of Axis #1 used as the reference axis and Axis #2 used as the interpolation axis.
Simulation result	Shows the simulation result. Changing the positioning data also changes the simulation result in synchronization. For 2-axis interpolation control, the reference axis is in the horizontal direction and the interpolation axis is in the vertical direction. For 1-axis control, time is in the horizontal direction and the axis speed is in the vertical direction. Use the scroll bars to move the display area.

REMARK

In the locus data for circular interpolation control, lines may be broken due to a data processing error during drawing.



HELPFUL OPERATION

When you want to try the command speeds (waveform) or addresses (locus) at the setting of the positioning data, you can set or change the positioning data while simultaneously checking the simulation result.

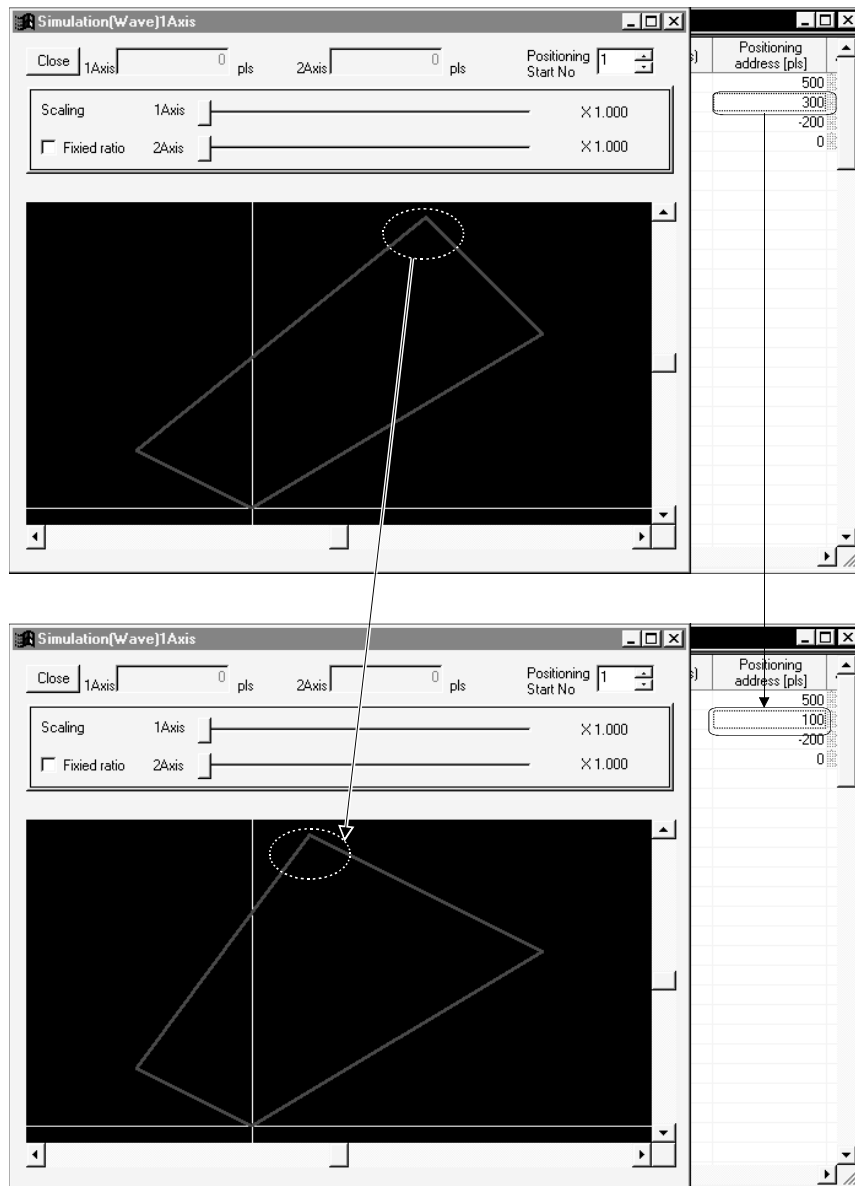

8.4 Block Start Data Setting

Set the block start data for controlling a positioning start and the condition data used as a condition for a special start.



- The block start data is equivalent to the start block data of the AD75.

8.4.1 Block start data



PURPOSE

Specify the positioning data No. as a point, and set the block start data which sets the starting condition, execution order and execution count to each point.
 You can set up to 50 points per block.
 There are blocks No. 0 to 4 per axis.



BASIC OPERATION

1. Choose the block start data.



2. Make settings in the block start data edit window.



DISPLAY/SETTING SCREEN

Point No.	Pattern	Data No.	Special start	Param	Condition data
1	1:CONT	1	0:Normal start	0	
2	0:END	11	1:COND start	1 (800) = (100000)	
3					
4					
5					
6					
7					
8					
9					
10					
11					
12					
13					
14					

Double-click the cell and make settings in the text box or list box.

When performing operation from the keyboard, enter the value and press the "Enter" key to determine the value.

For "Pattern" and "Special start", press the "space" key to display a list.

Make selection with the "↑" or "↓" key, and press the "Enter" key to determine the value.



DISPLAY/SETTING DATA

Item	Description
Point No.	Shows the point numbers 1 to 50.
Pattern	Select whether positioning control is ended at the point where positioning was completed or positioning control will be continued to the next point.
Data No.	Set the positioning data No. specified at the point. The setting range is positioning data No. 1 to 600.
Special Start	Choose the type of positioning control start per point. The selection range is 0 to 6. 0: Normal start 1: COND start 2: Wait start 3: SIMU start 4: FOR loop 5: FOR condition 6: NEXT start For the special start information, refer to QD75 User's Manual.
Param	When you set a conditional start, wait start, simultaneous start or FOR condition in Special Start, set any of the condition data No. 1 to 10 as its condition. (Refer to Section 8.4.2.) When you set FOR loop in Special Start, set the repeat count. The setting range is 0 to 255. Setting "0" makes the repeat count limitless.
Condition data	When you set a conditional start, wait start, simultaneous start or FOR condition in Special Start, the data of the parameter-set condition data No. appears. Double-clicking opens the condition data edit dialog box. When you set FOR loop in Special Start, the "repeat count" appears. Nothing appears when you set a normal start or NEXT start in Special Start.



HELPFUL OPERATION

The block start data to be edited defaults to block No. 0.

Perform the following operation to change the block to be edited to any of block No. 1 to 4.

1. Open the block start data edit window.
2. Click the [View] → [Select block start data no] menu.
3. Choose the block to be edited in the Block No. change dialog box, and click "OK" button.

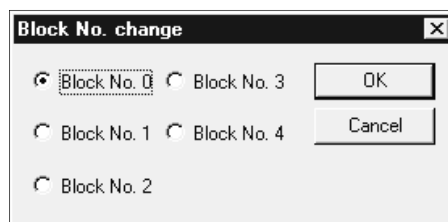

8.4.2 Condition data



PURPOSE

Set the condition data which will be the starting conditions of the conditional start, wait start, simultaneous start and FOR condition in the block start data.



BASIC OPERATION

1. Choose the block start data of the axis to which the condition data will be set.



2. Click the [Edit] → [Condition data edit] menu.
3. Choose the data No. to be set in the Condition data list dialog box.
4. Click the "Edit" button in the Condition data list dialog box.
5. Choose the condition operator and condition identifier in the Condition data edit dialog box, and set the condition values.
6. Click the "OK" button in the Condition data edit dialog box.
7. To exit, click the "Close" button in the Condition data list dialog box.



DISPLAY/SETTING SCREEN

[Condition data list dialog box]

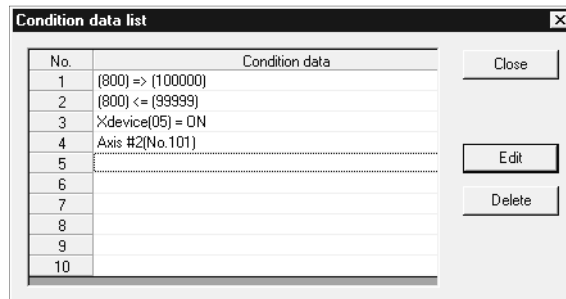

[Condition data edit dialog box]

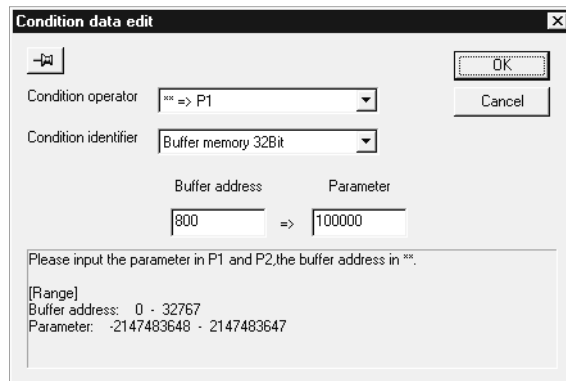



DISPLAY/SETTING DATA

Item	Description
No.	Shows the condition data No.
Condition data	Shows the condition data set in the Condition data edit dialog box.
"Edit" button	Click this button to display the Condition data edit dialog box.
"Delete" button	Click this button to delete the condition data at the cursor.
Condition operator	<p>Choose the type of the condition operator of the condition data.</p> <ul style="list-style-type: none"> • * *=P1 • * *!=P1 • * *<=P1 • * *>=P1 • P1<=* *<=P2 • * *<=P1, P2<=* * • Device=ON • Device=OFF • Simultaneous start axis set <p>* * indicates the value stored in buffer memory. P1 and P2 indicate parameters (values set as desired). Device indicates the X/Y device.</p>
Condition identifier	<p>Choose the object of the condition operator.</p> <ul style="list-style-type: none"> • If the condition operator is comparison between * * and P1 and/or P2 Choose the buffer memory size of 16 or 32 bits. • If the condition operator is device=ON/OFF Choose the device type of X device or Y device. • If the condition operator is simultaneous start, choose the axes to be started at the same time.
Text box	<p>Set the condition object to the condition operator.</p> <ul style="list-style-type: none"> • If the condition operator is comparison between * * and P1 and/or P2 Set the buffer memory address in * *. Set to P1 and/or P2 the value of the size set in Condition identifier. • If the condition operator is device=ON/OFF Set the device name. • If the condition operator is simultaneous start Set the positioning data No. of the axes to be started at the same time.
"OK" button	By clicking this button, the settings appear in the Condition data list dialog box.



HELPFUL OPERATION

When setting the condition data consecutively, click  in the Condition data edit dialog box.

Since this causes the Condition data edit dialog box to be kept open if you click the "OK" button, you can edit the condition data by switching it to the Condition data list dialog box.

8.5 Error Check



PURPOSE

Make error check to check the parameter settings, positioning data and block start data for mismatches and setting omissions.

For the error check range, refer to QD75 User's Manual.



BASIC OPERATION

1. Set the error-checked project as the active project on the project tree view.
(Refer to Section 5.2.)
2. Click the [Tool] → [Error check] menu.



DISPLAY/SETTING SCREEN

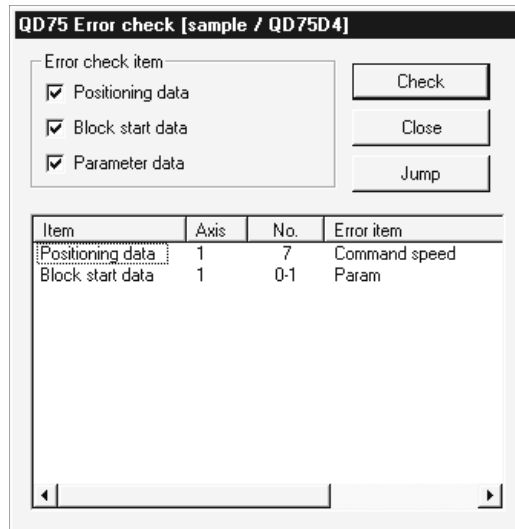

DISPLAY/SETTING DATA

Item	Description
Error check item	In the check box, set the data on which error check will be made.
"Check" button	Click this button to start error check.
"Jump" button	Click this button to show the error locations.
Error check result	When error check is completed, the number of errors and error locations appear. On the above screen, error locations are the command speed of axis #1 positioning data No. 7 and the parameter at point No. 1 of axis #1 block No. 0.

9. QD75 DATA WRITE/READ/VERIFY

Perform write to QD75/read from QD75/verify QD75 data, data write from QD75 buffer memory to flash ROM, and QD75 initialization.

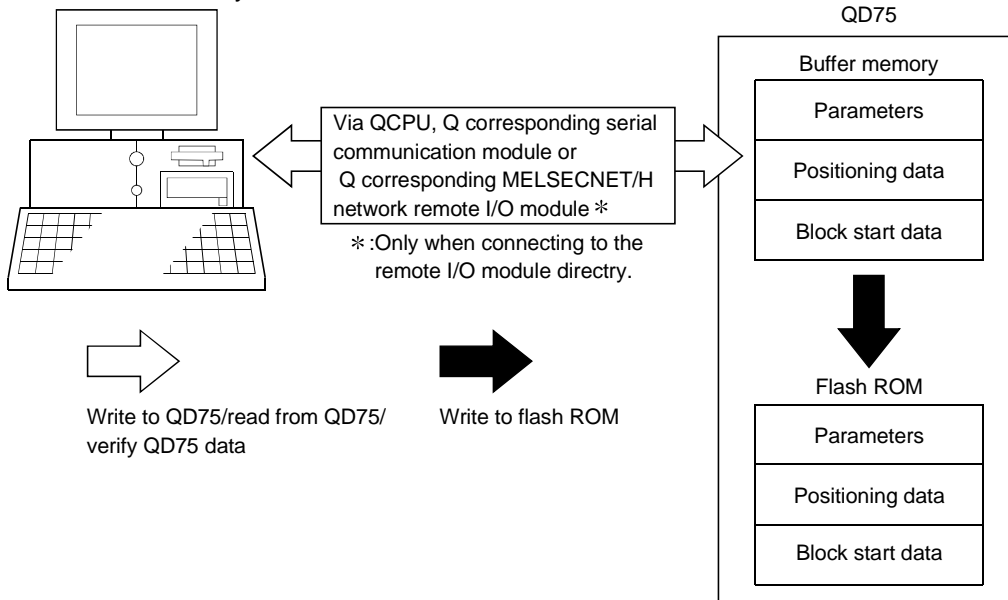

9.1 Write to QD75/Read from QD75/Verify QD75 Data



PURPOSE

Write, read and verify the data set in the project (parameters, positioning data, block start data) on an axis by axis basis.



- Write to QD75 executes a write to the QD75 which is set in the active project. When performing batch write to multiple QD75s, use the multi-module batch write function. (Refer to Section 11.1.4)
- Whether write to QD75 may be performed or not is determined by the PLC state check setting in Option setting. (Refer to Section 11.5)
- When trying operation while simultaneously changing the positioning data, you can use the positioning data test edit function to write only the positioning data during a test. (Refer to Section 11.7.2)



BASIC OPERATION

1. Place the QCPU in the STOP status.
When performing write to QD75 without putting the QCPU in the STOP status, change the PLC state check setting in Option setting.
2. As an active project, set the project used for write to QD75/read from QD75/verify QD75 data. Refer to Section 5.2 for the active project setting.
3. Click the [Online] → [Write to QD75] ()/[Read from QD75] ()/Verify QD75 data] () menu.
4. Set the data type and range in the QD75 Writing/Reading/Verify dialog box.
5. Click the "OK" button to start operation.
6. For QD75 data verify, the verify result appears.



DISPLAY/SETTING SCREEN

<Write form QD75>

<<Main>> tab screen

QD75 Writing [Sample / QD75D4]

Main | Positioning data | Block start data | Parameter data

Current type QD75D4 PLC type Q25HCPU I/O No. 0

Item

- Positioning data
- Block start data
- Parameter
- Flash Rom write

OK Cancel

<<Positioning data>> tab screen

Main | Positioning data | Block start data | Parameter data

Current type QD75D4 PLC type Q25HCPU I/O No. 0

Select item

- Axis #1 Positioning data 1 · 600
- Axis #2 Positioning data 1 · 600
- Axis #3 Positioning data 1 · 600
- Axis #4 Positioning data 1 · 600

<<Block start data>> tab screen

Main | Positioning data | Block start data | Parameter data

Current type QD75D4 PLC type Q25HCPU I/O No. 0

Selected item

- Axis #1 Block start data Block 0 only All
- Axis #2 Block start data Block 0 only All
- Axis #3 Block start data Block 0 only All
- Axis #4 Block start data Block 0 only All

<<Parameter data>> tab screen

Main | Positioning data | Block start data | Parameter data

Current type QD75D4 PLC type Q25HCPU I/O No. 0

Selected item

- Axis #1 Parameter data
- Axis #2 Parameter data
- Axis #3 Parameter data
- Axis #4 Parameter data

<Verify QD75 data>
[Verify result dialog box]

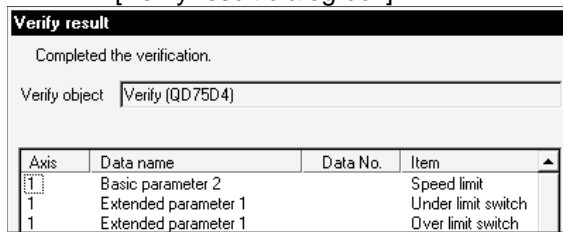

DISPLAY/SETTING DATA

Item	Description
Positioning data Block start data Parameter	Set the data used for write to QD75/read from QD75/verify QD75 data from positioning data, block start data and parameters. Block start data includes condition data.
"Flash-ROM write" check box	When performing write to QD75, set a request to write from buffer memory to flash ROM at the same time.
Current type	Set the model of the QD75 connected to the peripheral device and the range of write/read/verify.
<<Positioning data>> tab <<Block start data>> tab <<Parameter data>> tab	Click the corresponding tab to display the screen which is used to set the axes and ranges of the data for write to QD75/read from QD75/verify QD75 data.
<<Positioning data>> tab screen	Set the axes of the positioning data used for write to QD75/read from QD75/verify QD75 data. Also, set the positioning data No.s in the write/read/verify range on an axis by axis basis.
<<Block start data>> tab screen	Set the axes of the block start data used for write to QD75/read from QD75/verify QD75 data. Also, set the range of the QD75 write/read/verify block on an axis basis.
<<Parameter data>> tab screen	Set the axes used for write to QD75/read from QD75/verify QD75 data.
"OK" button	Click this button to start write to QD75/read from QD75/verify QD75 data.
Verify result dialog box	After QD75 data verify is completed, differences between the QD75 and project appear. The screen displays that the speed limit value of the axis #1 basic parameter 2 and the software stroke limit upper/lower limit value of the extended parameter 1 differ between the QD75 and project. Verify processing is suspended as soon as the number of mismatches reaches 600.



- The following data are saved in the peripheral device only and write to QD75/read from QD75/verify QD75 data cannot be performed.
M code comments
Positioning data comments

9.2 Flash ROM write request

**PURPOSE**

Issue the command to write the QD75 buffer memory data to the flash ROM. Write from buffer memory to flash ROM is batch-performed in the full ranges of the parameters, positioning data and block start data (including condition data).



- Whether the flash ROM request may be performed or not is determined by the PLC state check setting in Option setting. (Refer to Section 11.5)

**BASIC OPERATION**

1. Place the QCPU in the STOP status.
When performing the flash ROM write request without putting the QCPU in the STOP status, change the PLC state check setting in Option setting.
2. On the project tree view, set the required project as an active project. (Refer to Section 5.2)
3. Click the [Online] → [Flash ROM request] menu.
4. Click the "Action" button in the Flash ROM request dialog box.
5. Click the "Yes" button in the execution confirmation dialog box.

9.3 QD75 Initialization

**PURPOSE**

When the system is renewed, for example, initialize the QD75 flash ROM and buffer memory to place them in the factory-set status (default settings).



- Whether QD75 initialization may be performed or not is determined by the PLC state check setting in Option setting. (Refer to Section 11.5)

**BASIC OPERATION**

1. Place the QCPU in the STOP status.
When performing QD75 initialization without putting the QCPU in the STOP status, change the PLC state check setting in Option setting.
2. On the project tree view, set the required project as an active project. (Refer to Section 5.2)
3. Click the [Online] → [Initialize QD75] menu.
4. Click the "Action" button in the Initialize QD75 dialog box.
5. Click the "Yes" button in the execution confirmation dialog box.

10. POSITIONING DEBUGGING



Debug positioning operation by checking the parameters, positioning data and other data set to the QD75 for errors, monitoring the positioning operation, and performing various operation tests by positioning data test operation and JOG operation.



- All axes stop if a communications error occurs, e.g. SW□D5C-QD75P-E is forced to end, the peripheral device is powered off, or the connection cable is disconnected, in the test mode.
In addition, the test mode of the QD75 is canceled after the wait time (set value × 500ms) in Connection setup has elapsed.



**HELPFUL OPERATION (PART 1)**

If an error has occurred during monitoring or testing, perform the following operation.

1. Check the axis status using Operation monitor (refer to Section 10.2.2).
2. When the axis status indicated is error, click the "Message" button and check the error code and message.
3. For the error code, confirm the error cause and its corrective action using the error/warning help.
4. Click the [Online] → [Test] → [Error reset] → [Error reset #1 to #4] menu ( to ).
5. Remove the error cause according to the corrective action.

**HELPFUL OPERATION (PART 2)**

To turn off the M code during monitoring or testing, perform the following operation.

Click the [Online] → [Test] → [M code Off] → [M code #1 to #4 Off] menu ( to ).

**HELPFUL OPERATION (PART 3)**

To stop all operating axes during monitoring or testing due to an external equipment fault, etc. perform the following operation.

Click the [Online] → [Test] → [All axis stop] menu ().

10.1 QD75 Error Check



PURPOSE

Make an error check on the parameters, positioning data and block start data stored in the buffer memory of the specified QD75.
 Refer to QD75 User's Manual, for the action taken for the check results.



BASIC OPERATION

1. Choose the [Online] → [Error check QD75 data] menu ().
2. Clicking the corresponding QD75 in the System monitor dialog box shows the QD75 Error check dialog box.
 Refer to Error Check (Section 8.5) for the operation that follows.



DISPLAY/SETTING SCREEN

[System monitor dialog box]

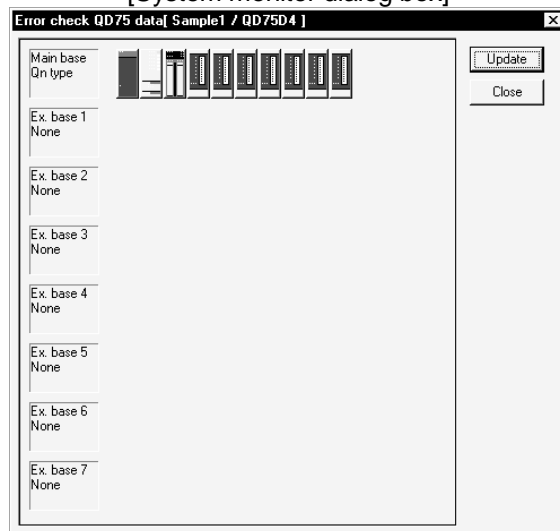

[QD75 Error check dialog box]

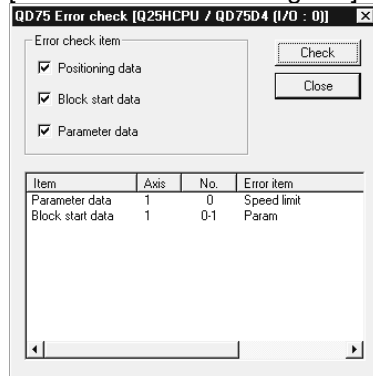

10.2 Monitor

Monitor the positioning data and block start data execution states on an axis by axis basis, or perform detailed monitor of the error histories, signal states, present values, speeds, etc. on a project basis.

10.2.1 Monitoring the positioning data/block start data



PURPOSE

From the positioning data/block start data edit window of any axis, monitor the positioning data No.s or block No.s and point No.s being executed.



BASIC OPERATION

1. Choose the positioning or block start data edit window.

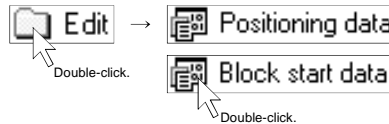

2. Click the [Online] → [Monitor] → [Monitor On/Off] menu ().
3. To exit, click the [Online] → [Monitor] → [Monitor On/Off] menu ().



DISPLAY/SETTING SCREEN

[For positioning data monitor]

No.	Pattern	CTRL method	SLV axis	ACC(ms)	DEC(ms)	Positioning address [pls]	Arc Address [pls]	Cc
1	1:CONT	1:ABS line1	-	0;1000	0;1000	40000	0	
2	1:CONT	1:ABS line1	-	0;1000	0;1000	20000	0	
3	1:CONT	1:ABS line1	-	0;1000	0;1000	5000	0	
4	1:CONT	1:ABS line1	-	0;1000	0;1000	10000	0	
5	1:CONT	1:ABS line1	-	0;1000	0;1000	30000	0	
6	1:CONT	1:ABS line1	-	0;1000	0;1000	0	0	
7	1:CONT	1:ABS line1	-	0;1000	0;1000	25000	0	
8	1:CONT	1:ABS line1	-	0;1000	0;1000	45000	0	
9	1:CONT	1:ABS line1	-	0;1000	0;1000	30000	0	
10	0:END	1:ABS line1	-	0;1000	0;1000	0	0	
11								



DISPLAY/SETTING DATA

Item	Description
Positioning data monitor/block start data monitor	For positioning data monitor, the positioning data in execution is highlighted. For block start data monitor, the point in execution is highlighted.

10.2.2 Operation monitor



PURPOSE

Monitor the feed present value, axis feed speed, axis status, positioning data No. executed last, error/warning code occurring currently, and M code of each axis. This monitor is used to confirm the basic axis states.



BASIC OPERATION

1. Choose Operation monitor.

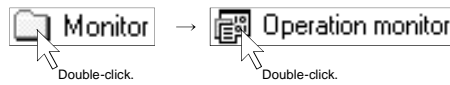

2. Click the "Monitor start" button.

3. To exit, click the "Monitor stop" button.



DISPLAY/SETTING SCREEN

[Operation monitor dialog box]

No	Pattern	CTRL method	SLV axis	ACC(ms)	DEC(ms)	Error	Warning	M code
#1	6	LOCUS	ABS line2	2	1000	1000	0	0
#2	0	END			1000	1000	0	0
#3	0	END			1000	1000	0	0
#4	0	END			1000	1000	0	0

[Comment dialog box]

Axis	Data No	M code No	M code comment
Axis #1	1	1	Paint
Axis #2	0	--	--
Axis #3	0	--	--
Axis #4	0	--	--

[Error/Warning message dialog box]

Axis	Error/Warning Code	Message
Axis #1	524	Control system setting error
	100	Start during operation
Axis #2	0	(Normal status)
	301	JOG speed limit value
Axis #3	0	(Normal status)
	0	(Normal status)
Axis #4	0	(Normal status)
	0	(Normal status)



DISPLAY/SETTING DATA

Item	Description
Title bar	Shows the project name and I/O address.
Feed present value	Indicates the feed present value. Buffer memory address (Axis #1): 800, 801
Axis speed	Indicates the feed speed. Buffer memory address (Axis #1): 812, 813
Axis status	Indicates the axis status. Buffer memory address (Axis #1): 809
No.	Indicates the positioning data No. in execution. Note that if other than the positioning data No. is specified for operation, its starting number is displayed. Buffer memory address (Axis #1): 835
Pattern	Indicates the positioning data pattern in execution. Buffer memory address (Axis #1): 838
CTRL method	Indicates the positioning data control method in execution. Buffer memory address (Axis #1): 838
SLV axis	Shows the interpolation axis when the control method is 2-axis linear interpolation control or circular interpolation control.
ACC DEC	Indicates the acceleration and deceleration times selected in the positioning data in execution. For the acceleration and deceleration times, refer to Parameter Setting (Section 8.1). Buffer memory address (Axis #1): 838
Error Warning	Shows the error and warning codes when an error and warning have occurred. "0" is displayed when no error/warning has occurred. The error/warning codes can be confirmed in [Help]. Buffer memory address (Axis #1/error): 806, Buffer memory address (Axis #1/warning): 807
M code	Indicates the M code of the positioning data in execution. Buffer memory address (Axis #1): 808
"History" button "Signal" button "#1 Operation status" button "#2 Operation status" button "#3 Operation status" button "#4 Operation status" button	Click the corresponding button to display the history, signal or operation monitor dialog box. The operation monitor dialog box appears per axis. Refer to Section 10.2.3 for history monitor. Refer to Section 10.2.4 for signal monitor. Refer to Section 10.2.5 for operation monitor.
"Comment" button	Click this button to display the dialog box which shows the positioning data or M code comments in execution.
"Message" button	Click this button at error occurrence to show the Error/Warning message dialog box.
"Monitor start" button	Click this button to start monitor.
"Monitor stop" button	Click this button to stop monitor.
Comment dialog box	Shows the positioning data or M code comments in execution.
Error/Warning message dialog box	Shows the error or warning which is occurring per axis. The error code and error name are in the top field. The warning code and error warning are in the bottom field.

10.2.3 History monitor



PURPOSE

Monitor the error, warning and start histories stored in the QD75 buffer memory during operation monitor.



BASIC OPERATION

1. Perform the basic operation in Section 10.2.2 to display the operation monitor window.
2. Click the "History" button on the operation monitor window.
3. Click the <<Error history>>/<<Warning history>>/<<Start history>> tab.



DISPLAY/SETTING SCREEN

[Error history monitor]

[Warning history monitor]



DISPLAY/SETTING DATA

Item	Description
Title bar	Shows the I/O address of the QD75 being monitored.
No.	Represents the order of errors/warnings which occurred since power-on. If more than 16 errors/warnings occurred, the older ones are deleted.
Axis	Shows the axis where the error/warning occurred. Buffer memory address (newest error): 1293 Buffer memory address (newest warning): 1358
Code	Shows the error/warning code. Buffer memory address (newest error): 1294 Buffer memory address (newest warning): 1359
Time	Shows the error/warning occurrence time in hour:minute:second format. Buffer memory address (newest error): 1295, 1296 Buffer memory address (newest warning): 1360, 1361
Message	Shows the error/warning name.



DISPLAY/SETTING SCREEN

[Start history monitor]

No.	Axis	Start	Mode	Time	R
1	1	QD75Win	Start No. 1	16:49:36	O
2	2	QD75Win	JOG operation	17:42:44	O
3					
4					
5					
6					
7					
8					
9					
10					
11					
12					
13					
14					
15					
16					



DISPLAY/SETTING DATA

Item	Description
Title bar	Shows the I/O address of the QD75 being monitored.
No.	Represents the order of starts since power-on. If there are more than 16 starts, the older ones are deleted.
Axis	Indicates the axis started. Buffer memory address: 1212
Start	Indicates the start command destination. The command destination is the PLC CPU, peripheral device or external signal. Buffer memory address: 1212
Mode	Indicates the type of operation started. The positioning data No. is displayed for operation which uses the positioning data. Buffer memory address: 1213
Time	Indicates the start occurrence time in hour:minute:second format. Buffer memory address: 1214, 1215
Result	Shows OK for a normal start. Shows the error code when an error occurs. The definition of the error code displayed can be confirmed by the help function. Buffer memory address: 1216

10.2.4 Signal monitor



PURPOSE

Monitor the I/O signals (X/Y device), external I/O signals and status signals of the QD75.

For the signals, refer to QD75 User's Manual.



BASIC OPERATION

1. Perform the basic operation in Section 10.2.2 to display the operation monitor window.
2. Click the "Signal" button in the operation monitor window.
3. Click the <<X Device>>/<<Y Device>>/<<External I/O signal>>/<<Status signal>> tab.



DISPLAY/SETTING SCREEN

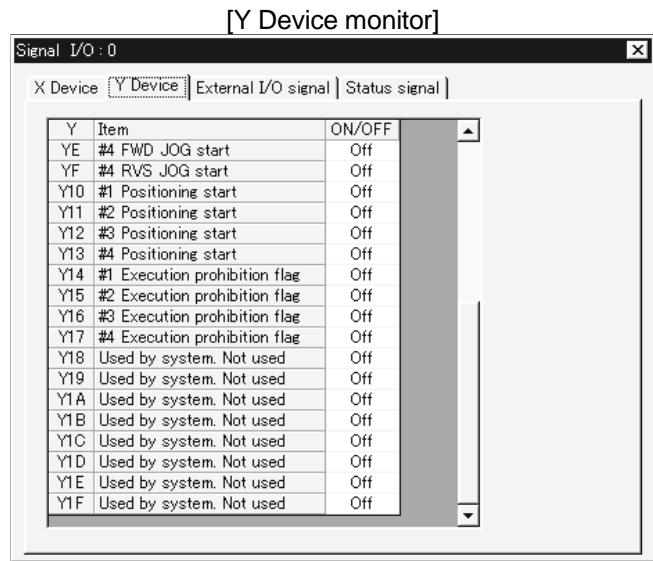
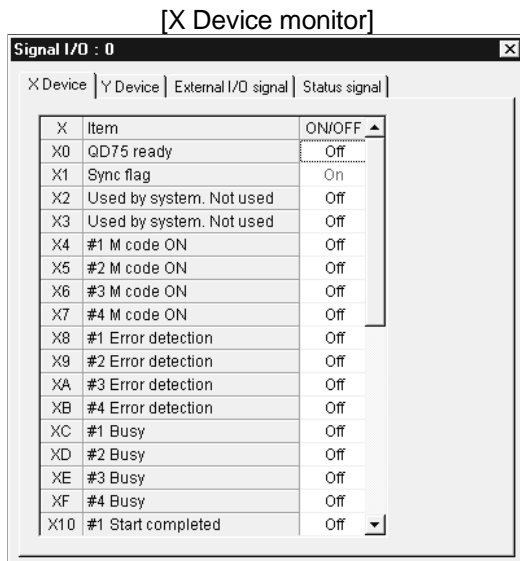

DISPLAY/SETTING DATA

Item	Description
Title bar	Shows the I/O address of the QD75 being monitored.
X Device	Displays On/Off states of the QD75 input signals.
Y Device	Displays On/Off states of the QD75 output signals.



DISPLAY/SETTING SCREEN

[External I/O signal monitor]

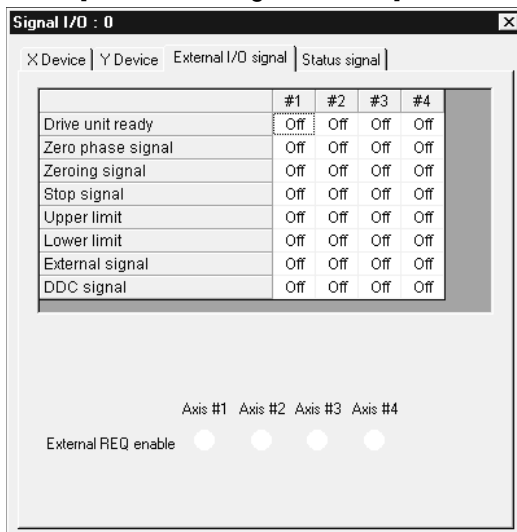

DISPLAY/SETTING DATA

Item	Description
Title bar	Shows the I/O address of the QD75 being monitored.
External I/O signal	Shows the On/Off states of the external I/O signals of the QD75. Buffer memory address (Axis #1): 816
External REQ enabled	Shows whether the start, V/P switch and P/V switch commands given by the external start signals are valid (●) or invalid (○). Buffer memory address (Axis #1): 1505



DISPLAY/SETTING SCREEN

[Status signal monitor]

Signal I/O : 0				
X Device	Y Device	External I/O signal	Status signal	
	#1	#2	#3	#4
Velocity control flag	Off	Off	Off	Off
V/P switching latch flag	Off	Off	Off	Off
Command in-position flag	Off	Off	Off	Off
OPR request flag	On	On	On	On
OPR completed flag	Off	Off	Off	Off
P/V switching latch flag	Off	Off	Off	Off
Axis warning detected	Off	On	Off	Off
Velocity change 0 flag	Off	Off	Off	Off



DISPLAY/SETTING DATA

Item	Description
Title bar	Shows the I/O address of the QD75 being monitored.
Status signal	Shows the On/Off states of the status signals of the QD75. Buffer memory address (Axis #1): 817

10.2.5 Axis operation monitor



PURPOSE

Monitor the settings, states and others of the axis control data, velocity/position control, position/velocity control, original point return and JOG/MPG operation during operation monitor.

With operation monitor, you can check the detailed states of operation and the QD75 settings made with the sequence program or peripheral device.

For each monitor item, refer to QD75 User's Manual.



BASIC OPERATION

1. Perform the basic operation in Section 10.2.2 to display the operation monitor window.
2. Click the "<Axis #1 to #4> Operation" button in the operation monitor window.
3. Click the <<Axis control data>>/<<Velocity/position control>>/<<Position/velocity control>>/<<OPR>>/<<JOG/MPG>> tab in the Operation dialog box.



DISPLAY/SETTING SCREEN

[Axis control data monitor]

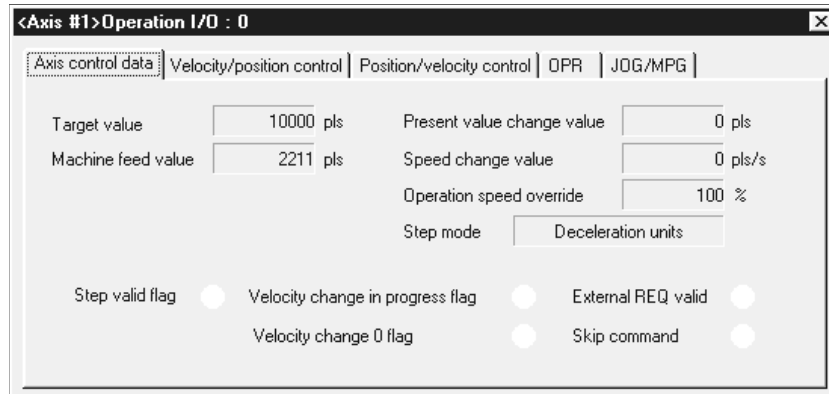

(Screen example shows <Axis #1> Operation monitor.)



DISPLAY/SETTING DATA

Item	Description
Title bar	Shows the I/O address of the QD75 being monitored.
Target value	Shows the destination for positioning control. For velocity/position switching control or position/velocity switching control, "0" is displayed for velocity control and the destination appears for position control. "0" is shown for other operations. Buffer memory address (Axis #1): 818, 819
Machine feed value	Indicates the current position whose original point is the inherent position determined by the machine (mechanical coordinates). On completion of OPR, this value indicates the original point address. Buffer memory address (Axis #1): 802, 803
Present value change address	Shows the feed present value changed with the positioning start No. 9003. Buffer memory address (Axis #1): 1506, 1507
Velocity change value	Shows the value of speed change made during positioning operation or JOG operation. Buffer memory address (Axis #1): 1514, 1515
Operational speed override	Indicates the override speed set in the sequence program. Buffer memory address (Axis #1): 1513
Step mode	Indicates the type of the step operation set in the sequence program. Buffer memory address (Axis #1): 1544
Step valid flag	Shows that the step operation set in the sequence program is valid. ● (ON) indicates that the step operation is valid. Buffer memory address (Axis #1): 1545
Velocity change in progress flag	Shows ● (ON) during speed changing. Buffer memory address (Axis #1): 831
Velocity change 0 flag	Shows ● (ON) when the speed is changed to 0 for speed changing. Buffer memory address (Axis #1): 817
External REQ valid	Shows that the external command signal set in the sequence program is valid. ● (ON) indicates that the start, velocity/position switching or position/velocity switching by the external command signal is valid. Buffer memory address (Axis #1): 1505
Skip command	Indicates the skip command given in the sequence program. Shows ● (ON) when the skip command is given. Buffer memory address (Axis #1): 1547



DISPLAY/SETTING SCREEN

[Position/velocity control monitor]

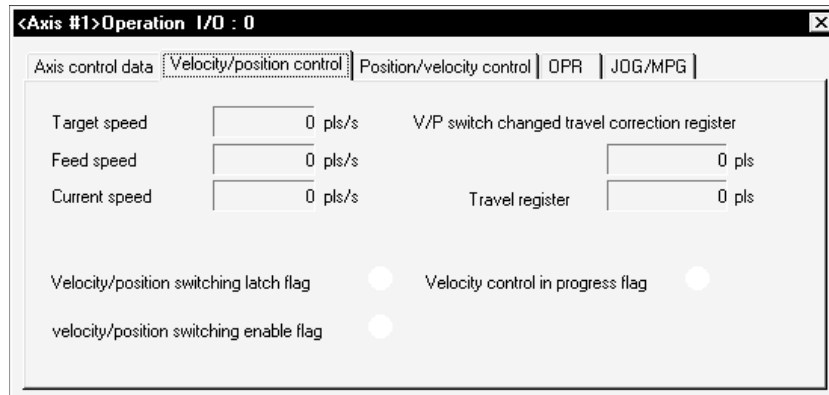

(Screen example shows <Axis #1> Operation monitor.)



DISPLAY/SETTING DATA

Item	Description
Target speed	Indicates the target speed for positioning data, OPR or JOG operation. For interpolation control, the composite speed or reference axis speed is displayed for the reference axis and 0 appears for the interpolation axis. Buffer memory address (Axis #1): 820, 821
Feed speed	Shows the speed of the axis operating actually in any operation. For interpolation control, the composite speed or reference axis speed is displayed for the reference axis and 0 appears for the interpolation axis. Buffer memory address (Axis #1): 804, 805
Current speed	Indicates the current speed. For interpolation control, the composite speed or reference axis speed is displayed for the reference axis and 0 appears for the interpolation axis. 0 appears for JOG operation or MPG operation. Buffer memory address (Axis #1): 810, 811
V/P switch changed travel correction register	Indicates the travel distance under position control when velocity control is changed to position control during velocity/position switching control. Buffer memory address (Axis #1): 814, 815
Travel register	Indicates the value set to the velocity/position switching control travel correction register in the sequence program. Buffer memory address (Axis #1): 1526, 1527
Velocity/position switching latch flag	Indicates the velocity/position switching latch flag for the status signal. ● (ON) indicates that velocity control is switched to position control. Buffer memory address (Axis #1): 817
Velocity/position switching enable flag	Indicates the velocity/position switching enable flag set in the sequence program. ● (ON) indicates that switching by the velocity/position switching signal is valid. Buffer memory address (Axis #1): 1528
Velocity control in progress flag	Indicates the signal for differentiating between velocity control and position control. ● (ON) during velocity control. Buffer memory address (Axis #1): 817(b0)



DISPLAY/SETTING SCREEN

[Position/velocity control monitor]

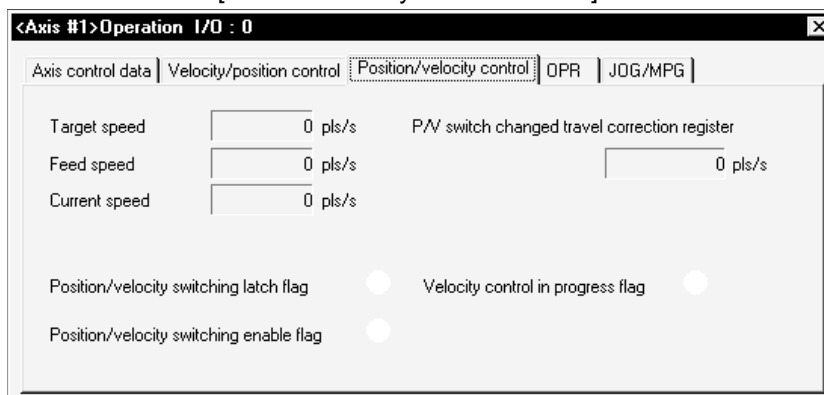

(Screen example shows <Axis #1> Operation monitor.)



DISPLAY/SETTING DATA

Item	Description
Target speed	Indicates the target speed for positioning data, OPR or JOG operation. For interpolation control, the composite speed or reference axis speed is displayed for the reference axis and 0 appears for the interpolation axis. Buffer memory address (Axis #1): 820, 821
Feed speed	Shows the speed of the axis actually operating in any operation. For interpolation control, the composite speed or reference axis speed is displayed for the reference axis and 0 appears for the interpolation axis. Buffer memory address (Axis #1): 804, 805
Current speed	For interpolation control, the composite speed or reference axis speed is displayed for the reference axis and 0 appears for the interpolation axis. 0 appears for JOG operation or MPG operation. Buffer memory address (Axis #1): 810, 811
P/V switch changed travel correction register	Displays the contents of register which stores the position/speed change control designated speed as set in the sequence program. Buffer memory address (Axis #1): 1530, 1531
Position/velocity switching latch flag	Indicates the position/velocity switching latch flag for the status signal. ● (ON) indicates that position control is switched to velocity control. Buffer memory address (Axis #1): 817
Position/velocity switching enable flag	Indicates the position/velocity switching enable flag set in the sequence program. ● (ON) indicates that switching by the position/velocity switching signal is valid. Buffer memory address (Axis #1): 1532
Velocity control in progress flag	Indicates the signal for differentiating between velocity control and position control. ● (ON) during velocity control. Buffer memory address (Axis #1): 817(b0)

 DISPLAY/SETTING SCREEN

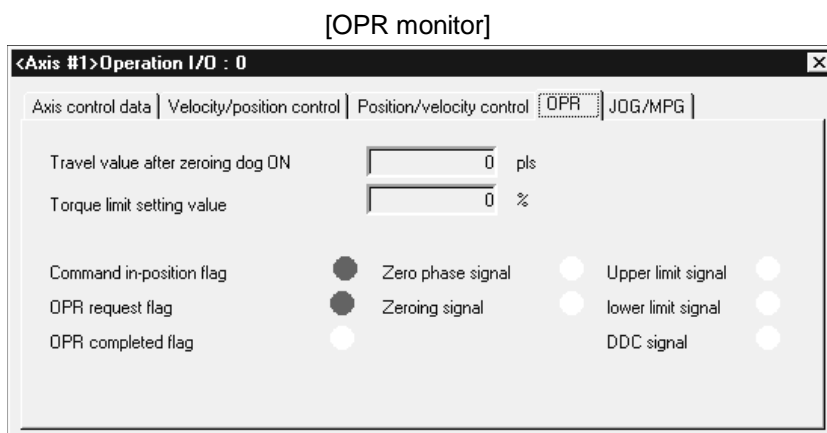

(Screen example shows <Axis #1> Operation monitor.)

 DISPLAY/SETTING DATA

Item	Description
Travel value after near point dog ON	Indicates the travel distance of the axis during OPR from the position where the limit switch is turned on by the dog to the position where OPR is completed. Buffer memory address (Axis #1): 824, 825
Torque limit setting value	Shows the torque limit setting or torque change value. Buffer memory address (Axis #1): 826
Command in-position flag OPR request flag OPR completed flag	Displays the status signals related to OPR. ●: ON ○: OFF Buffer memory address (Axis #1): 817
Zero phase signal Near point signal Upper limit signal Lower limit signal DDC signal	Shows the external I/O signals related to OPR. ●: ON ○: OFF Buffer memory address (Axis #1): 816



DISPLAY/SETTING SCREEN

[JOG/MPG monitor]

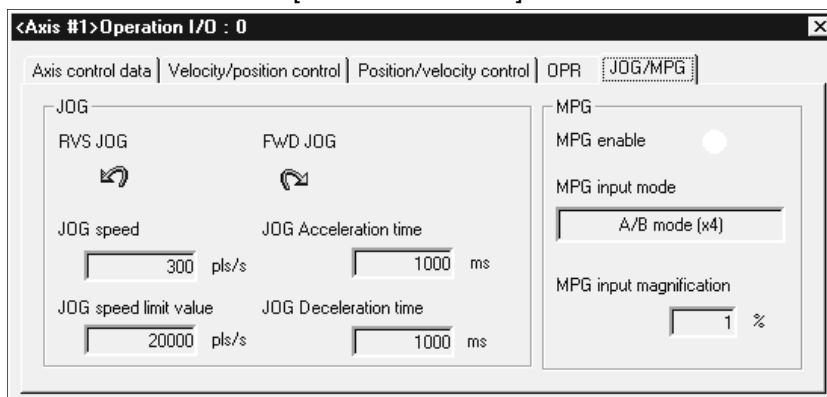

(Screen example shows <Axis #1> Operation monitor.)



DISPLAY/SETTING DATA

Item	Description
FWD JOG RVS JOG	Indicates the direction during JOG operation in the sequence program.
JOG speed	Indicates the axis speed during JOG operation in the sequence program. Buffer memory address (Axis #1): 1518, 1519
JOG speed limit value	Indicates the JOG operation limit value set in the extended parameters 2. Buffer memory address (Axis #1): 48, 49
JOG Acceleration time JOG Deceleration time	Shows the acceleration time and deceleration time set in the extended parameters 2. Buffer memory address (Axis #1): 50/51
MPG enable	Shows if manual pulse operation is allowed or not. Permission setting in the test mode from the peripheral device is not displayed. Buffer memory address (Axis #1): 1524
MPG input mode	Shows the MPG pulse input mode set in the extended parameters 1. Buffer memory address (Axis #1): 33
MPG input magnification	Indicates the factor per MPG output pulse set in the sequence program is multiplied by to find the number of input pulses. Buffer memory address (Axis #1): 1522, 1523

10.3 Sampling Monitor

Monitor the ON/OFF of any registered signals and the buffer memory values while simultaneously sampling them.

10.3.1 Sampling signal monitor



PURPOSE

You can monitor the ON/OFF of the specified X/Y devices, external I/O signals and status signals in the timing chart.



BASIC OPERATION

1. Choose Sampling monitor (signal).

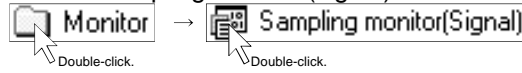

2. Click the "Setup" button in the Sampling monitor (signal) window.
3. Set the signals in the Sampling monitor dialog box.
4. Click the [Online] → [Monitor] → [Monitor On/Off] menu ().
5. Check the monitor results.
6. To exit, click the [Online] → [Monitor] → [Monitor On/Off] menu ().



DISPLAY/SETTING SCREEN

[Sampling monitor (signal)]

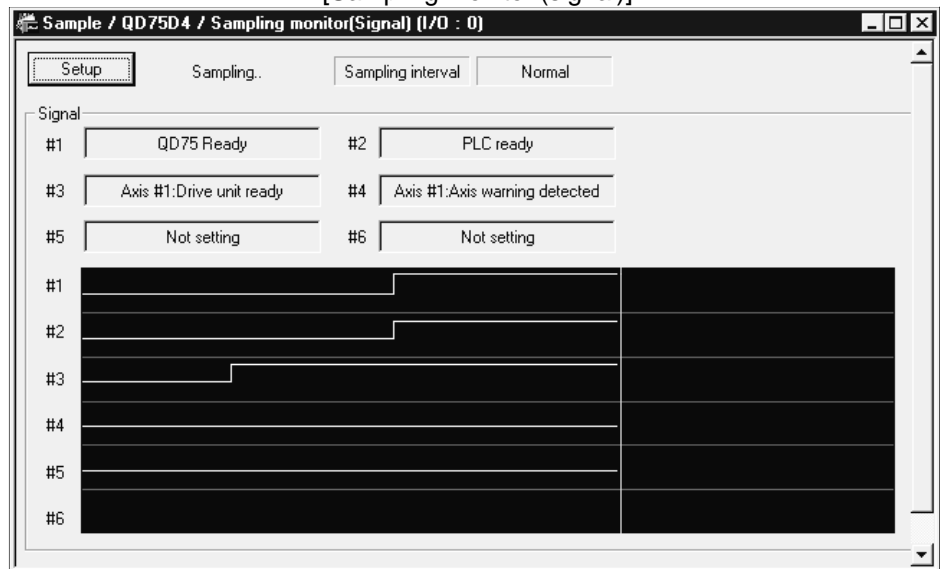

[Sampling monitor dialog box]

**DISPLAY/SETTING DATA**

Item	Description
"Setup" button	Click this button to display the Sampling monitor dialog box.
Sampling monitor result	ON/OFF states are shown in the HIGH/LOW timing chart. The sampling cycle time changes with the sampling interval. The timing chart is enlarged or reduced according to the screen size.
Sampling interval	Choose the sampling interval from among "Fastest", "Faster", "Normal", "Slower" and "Slowest".
Signal Select	Choose the types of the sampled signals from the X device, Y device, external I/O signal and status signal.
Signal item	Choose the signals to be sampled.
"OK" button	Click this button to close the Sampling monitor dialog box and display the settings in the Sampling monitor (signal) window.

10.3.2 Sampling buffer monitor



PURPOSE



You can monitor the buffer memory storage values of the specified QD75 as waveform data.

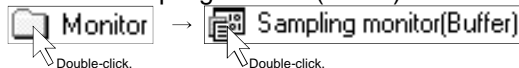

BASIC OPERATION

1. Choose Sampling monitor (Buffer).



2. Click the "Setup" button in the Sampling monitor (Buffer) window.
3. Set the buffer memory addresses, upper limit value and lower limit value in the Sampling Buffer area data setting dialog box.
4. Click the [Online] → [Monitor] → [Monitor On/Off] menu ().
5. Check the monitor results.
6. To exit, click the [Online] → [Monitor] → [Monitor On/Off] menu ().



DISPLAY/SETTING SCREEN

[Sampling monitor (Buffer)]

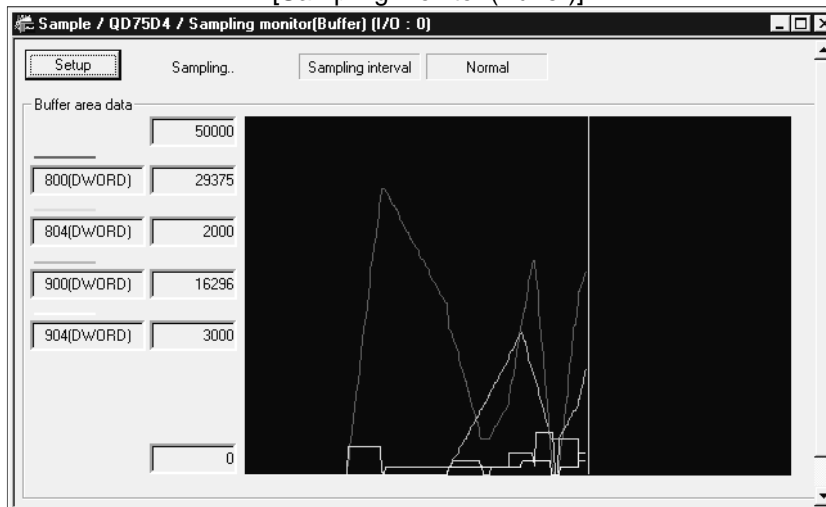

[Sampling Buffer area data setting dialog box]

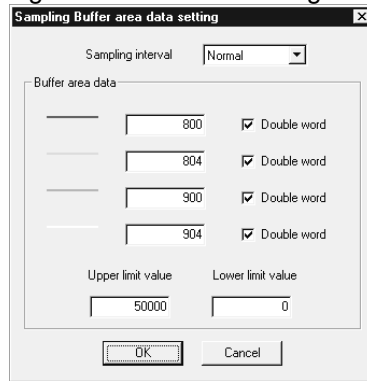

DISPLAY/SETTING DATA

Item	Description
"Setup" button	Click this button to display the Sampling Buffer area data setting dialog box.
Sampling monitor result	Shows the buffer memory values as waveform data. The sampling cycle time changes with the sampling interval. The waveform data are enlarged or reduced according to the screen size.
Sampling interval	Choose the sampling interval from among "Fastest", "Fast", "Normal", "Slow" and "Slowest".
Buffer area data	Set the QD75 buffer memory addresses and device sizes to be sampled. Click the unchecked check box when monitoring double word data such as the feed present value and feed speed. The setting range is buffer memory addresses 800 to 1499. The setting range for double-word data is 800 to 1498, and only even addresses may be set. Set to 0 when not performing sampling.
Upper Limit Lower Limit	Set the upper and lower limit values to be displayed as waveform data. The waveform data near the upper limit value may not appear when the sampling screen is redisplayed by switching the windows, for example. In that case, set the upper limit value to a value larger than the sampled value, and also change the lower limit value to reduce the difference between the upper and lower limit values.
"OK" button	Click this button to close the Sampling Buffer area data setting dialog box and display the settings in the Sampling monitor (Buffer) window.



HELPFUL OPERATION

If you do not know the buffer memory addresses of the QD75, you can set them by the following operation.

Right-click the text box in the Sampling Buffer area data setting dialog box.

The buffer memory addresses and device sizes of the data selected from the right-click menu are set automatically.

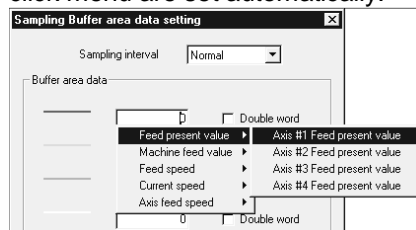

10.4 Test

Place the QD75 in the test mode during operation monitor, and test the positioning start, present value change, speed change, OPR, JOG or MPG operation. Each operation can be tested in the cableless test mode using just the QD75.

 CAUTION

- Before performing the OPR, JOG operation, positioning data or other test in the test mode, read the manual carefully, fully ensure safety, and set the PLC CPU to STOP. Incorrect operations can damage the machine or cause an accident.

(1) Test mode ON operation

Perform the following operation to place the QD75 in the test mode.

1. Set the required project as the active project.
Refer to Section 5.2 for the active project setting.
2. Click the [Online] → [Test] → [Test On/Off] menu ().
3. Click the "Yes" button in the all displayed window closing confirmation dialog box.
4. Click unchecked "Agreement with Module data" in the following dialog box.

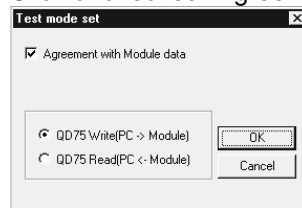

5. Choose QD75 Write or QD75 Read and click the the "OK" button.
Refer to Section 9.1 for QD75 write and QD75 read.
6. Click the "OK" button in the test mode confirmation dialog box.
7. To exit from the test mode, click the [Online] → [Test] → [Test On/Off] menu().

 Point

- (1) When conducting a test in the cableless mode, you cannot perform start, velocity/position switching and position/velocity switching under the control of external input signals and OPR which requires near point dogs and zero phase signal.
Since the feed present value cannot be cleared by OPR, make the present value change test (refer to Section 10.4.2) to clear it.
- (2) If an error occurred due to cable disconnection during a test in the wiring-less mode, an attempt to shift to the test mode again after cable reconnection may display the dialog box "The module is already under TEST MODE." In this case, shift to the test mode after resetting the PLC CPU.
- (3) In the test mode, JOG or other operation may respond slower depending on the running condition of the personal computer.
In such a case, take the following actions.
 - Close all applications except SW□D5C-QD75P-E so that they are not run concurrently.
 - Set the transmission speed to 38.4kbps or higher in Connection Setup (refer to Section 7.1).



HELPFUL OPERATION

Perform the following operation when you want to test the positioning data or block start data before installing external equipment such as the servo amplifiers and motors.

1. Click the [Online] → [Test] → [Cableless mode] menu.
2. Choose the test mode by performing the above operation.
3. The operation that will follow is the same as in the corresponding test. Refer to the corresponding pages.
4. To finish, exit from the test mode and click the [Online] → [Test] → [Cableless mode] menu.

10.4.1 Positioning start test





PURPOSE

Specify the positioning data No. or block start data point No. and perform test operation.



BASIC OPERATION

1. Put the QD75 in the test mode in accordance with Section 10.4 (1).
2. Click the [Online] → [Test] → [Operation test] → [Operation test #1 to #4] menu ( to ).
3. Click the <<Position start>> tab in the TEST MODE setting dialog box.
4. Make external command setting when to enable start, velocity/position switching or position/velocity switching under the control of external command signal.
5. Choose Start mode.
6. Set Data No. or Block start No. and multiple axis sync start data No. according to Start mode.
7. When using a step start to perform test operation, click the unchecked "Step Start" check box to choose the step start type.
8. Clicking the "Start" button starts test operation from the specified positioning data or point.
9. To exit, click the "Close" button.



DISPLAY/SETTING SCREEN



DISPLAY/SETTING DATA

Item	Description
Monitor	Shows the axis status.
Start mode	Choose the start mode of test operation. <ul style="list-style-type: none"> • Positioning start Test operation is started from the specified positioning data No. • Block start Test operation is started from the specified block point No. • Multiple axis sync start data No. Test operation is started from the positioning data No. specified per axis.
Data No.	Set the positioning data No. for the positioning start mode.
Block No.	Set the block No. for the block start mode.
Point No.	Set the point No. for the block start mode.
Multiple axis sync start data No.	Set the positioning data No. to each axis for the multiple axis sync start mode.
"EXT. command" button	Clicking this button shows the external command dialog box and allows you to set external command enable, velocity/position switching enable or position/velocity switching enable.
"Continue" button	Click this button during step standby to make a step start from the next positioning data No.
"Start" button	Click this button to start test operation from the preset positioning data No. or point No.
"Re-start" button	Click this button during an axis stop to resume test operation from the stop position.
"Break off" button	Click this button to suspend positioning control during test operation.
"Skip" button	Click this button at a step start to skip over continuous positioning control or continuous locus control to the next positioning data. Skip is valid up to the positioning data next to the end of the operation pattern.

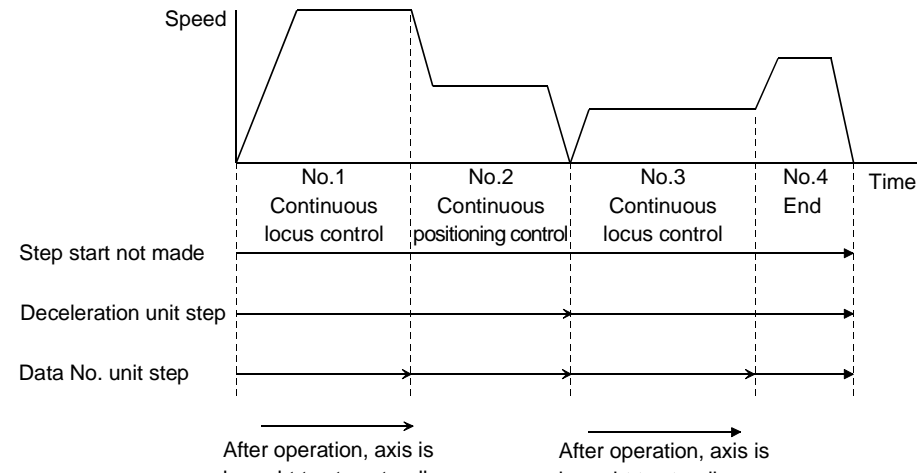
Item	Description
<p>Step start REQ.</p>	<p>When performing a step start, click the unchecked step start check box. When you made it valid, choose the step start type.</p> <ul style="list-style-type: none"> • Data No. units Independently of the operation pattern, operation is started from the specified positioning data No., and is performed and brought to a step standby status per data. • Deceleration units When the operation pattern is continuous locus control, test operation is performed up to continuous positioning control or the last positioning data. 
<p>"All axis stop" button</p>	<p>Click this button to stop all axes.</p>
<p>"Stop" button</p>	<p>Click this button to stop the axis. Clicking the "Re-start" button resumes test operation from the stop position</p>
<p><<Feed present value CHG>> tab <<Speed CHG>> tab <<OPR>> tab <<JOG/MPG>> tab</p>	<p>Click the tab to show the corresponding test screen. Present value change test Refer to Section 10.4.2. Speed change test Refer to Section 10.4.3. OPR test Refer to Section 10.4.4. JOG/MPG test Refer to Section 10.4.5.</p>

10.4.2 Present value change test





PURPOSE

Change the feed present value of the QD75 to the specified address.



BASIC OPERATION

1. Place the QD75 in the test mode in accordance with Section 10.4 (1).
2. Click the [Online] → [Test] → [Operation test] → [Operation test #1 to #4] menu ( to ).
3. Click the <<Feed present value CHG>> tab in the TEST MODE setting dialog box.
4. Type a new value in the text box and click the "Present-value change" button.
5. To exit, click the "Close" button.



DISPLAY/SETTING SCREEN

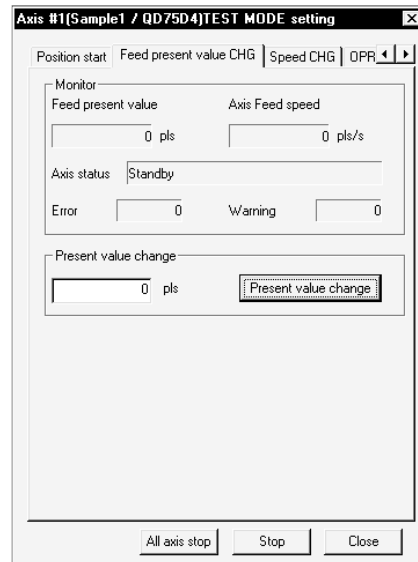

DISPLAY/SETTING DATA

Item	Description
Monitor	Shows the axis status.
Present value change	Set a new feed present value.
"Present value change" button	Click this button to change the present value.
"All axis stop" button	Click this button to stop all axes.
"Stop" button	Click this button to stop the axis.
<<Position start>> tab	Click the tab to show the corresponding test screen.
<<Speed CHG>> tab	Positioning start test.....Refer to Section 10.4.1.
<<OPR>> tab	Speed change test.....Refer to Section 10.4.3.
<<JOG/MPG>> tab	OPR test.....Refer to Section 10.4.4.
	JOG/MPG test.....Refer to Section 10.4.5.

10.4.3 Speed change test



PURPOSE

Make a speed and/or acceleration/deceleration time change to the axis operating in the positioning start, OPR or JOG operation test to check the adequate speed and/or acceleration/deceleration time.



BASIC OPERATION

1. Place the QD75 in the test mode in accordance with Section 10.4 (1).
2. Click the [Online] → [Test] → [Operation test] → [Operation test #1 to #4] menu (to).
3. Perform positioning start test (refer to Section 10.4.1), OPR test (refer to Section 10.4.4) or JOG/MPG operation test (refer to Section 10.4.5) in the TEST MODE setting dialog box.
4. Click the <<Speed CHG>> tab in the TEST MODE setting dialog box.
5. When changing the acceleration/deceleration time, click the unchecked "ACC/DEC time set enable" check box and set the acceleration/deceleration time.
6. Make a speed change test on the running axis.
7. To exit, click the "Close" button.



DISPLAY/SETTING SCREEN

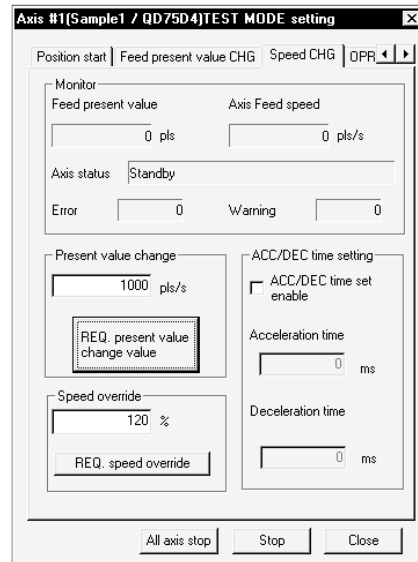



DISPLAY/SETTING DATA

Item	Description
Monitor	Shows the axis status.
Speed change	Set a new speed to replace the command speed, OPR speed or JOG operation speed of the running axis. The speed limit value is changed if the value is greater than the speed limit value set in basic parameters 2.
"REQ. speed change" button	Click this button to change the speed.
Speed override	Set the multiplying factor (%) of the speed overriding the command speed, OPR speed or JOG operation speed. Override also influences the new speed resulting from speed change. The override value once executed is valid during the test mode. The setting range is 1 to 300%.
"REQ. speed override" button	Click this button to execute override. Clicking this button in the standby status of the axis makes the override speed valid at the next start. A speed change is also made when this button is clicked for the running axis.
"ACC/DEC time set enable" check box	Used to set whether an acceleration/deceleration time change is enabled or disabled at a speed change. Click the unchecked check box to change the acceleration/deceleration time when a speed change is made.
Acceleration time Deceleration time	Set the acceleration time and deceleration time to be changed as soon as a speed change is made. When "ACC/DEC time set enable" is disabled (not checked), the setting is invalid.
"All axis stop" button	Click this button to stop all axes.
"Stop" button	Click this button to stop the axis.
<<Position start>> tab	Click the tab to show the corresponding test screen.
<<Feed present value CHG>> tab	Positioning start test..... Refer to Section 10.4.1. Present value change test Refer to Section 10.4.2.
<<OPR>> tab	OPR test..... Refer to Section 10.4.4.
<<JOG/MPG>> tab	JOG/MPG test..... Refer to Section 10.4.5.

10.4.4 OPR test





PURPOSE

Perform an OPR test to set up an original point and correct the preset OPR basic parameters and OPR extended parameters.



BASIC OPERATION

1. Place the QD75 in the test mode in accordance with Section 10.4 (1).
2. Click the [Online] → [Test] → [Operation test] → [Operation test #1 to #4] menu ( to ).
3. Click the <<OPR>> tab in the TEST MODE setting dialog box.
4. Check the OPR method, OPR speed and Original point address.
5. Choose the OPR type and click the "REQ. OPR" button.
6. To exit, click the "Close" button.



DISPLAY/SETTING SCREEN

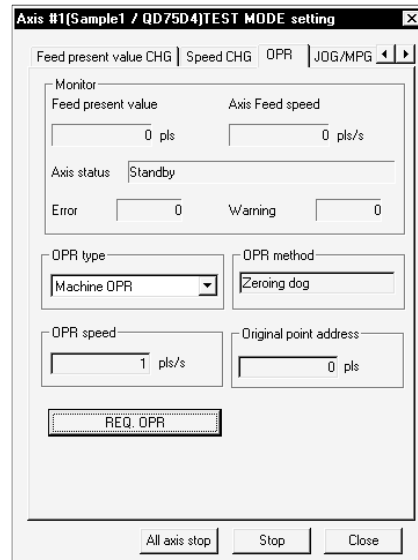



DISPLAY/SETTING DATA

Item	Description
Monitor	Shows the axis status.
OPR type	Chose the type of a starting method used in the OPR test. • Machine OPR OPR is performed using the dog or zero phase signal depending on the OPR method. Performed when the original point is set up. • High speed OPR Operation of positioning to the original point is performed in the travel distance calculated from the mechanical feed distance and the original point address set to the OPR basic parameters after the original point has been set up.
"REQ. OPR" button	Click this button to start OPR set for the OPR method.
OPR method OPR speed Original point address	Show the data set in the OPR basic parameters.
"All axis stop" button	Click this button to stop all axes.
"Stop" button	Click this button to stop the axis.
<<Position start>> tab	Click the tab to show the corresponding test screen.
<<Feed present value CHG>> tab	Positioning start test.....Refer to Section 10.4.1. Present value change testRefer to Section 10.4.2.
<<Speed CHG>> tab	Speed change testRefer to Section 10.4.3.
<<JOG/MPG>> tab	JOG/MPG test.....Refer to Section 10.4.5.



HELPFUL OPERATION

The following operation example is given for original point setup when the OPR method is the count type 2).

1. Perform steps 1 to 5 in BASIC OPERATION in this section to make an OPR test of the machine OPR type.
2. If there is a difference between the position of the original point set up in the OPR test and the expected position, perform JOG/MPG operation test(refer to Section 10.4.5) to correct the position.
3. Check the difference between the feed present value and original point address.
4. Make correction of the difference to "Travel distance after DOG" in the OPR extended parameters.

10.4.5 JOG/MPG operation test



PURPOSE

When debugging positioning control by JOG or MPG operation, you can conduct the following tests.

- Forward/reverse direction checking
- Checking of the ON/OFF of the external input signals such as upper/lower limit switch, zero phase and dog signals
- Speed and acceleration/deceleration operation tests
- Measurement of backlash compensation by forward or reverse operation
- Measurement of accurate addresses and travel distances



BASIC OPERATION

1. Place the QD75 in the test mode in accordance with Section 10.4 (1).
2. Click the [Online] → [Test] → [Operation test] → [Operation test #1 to #4] menu (to).
3. Click the <<JOG/MPG>> tab in the TEST MODE setting dialog box.
4. When performing JOG operation, set "1" or more for JOG velocity and "0" for Inching value, and press the "FWD JOG" or "RVS JOG" button.
5. When performing inching operation, set the inching travel value and press the "FWD JOG" or "RVS JOG" button.
6. When performing MPG operation, set the MPG input magnification, click unchecked MPG Enable flag, and use the manual pulse generator.
7. To exit, click the "Close" button.



DISPLAY/SETTING SCREEN

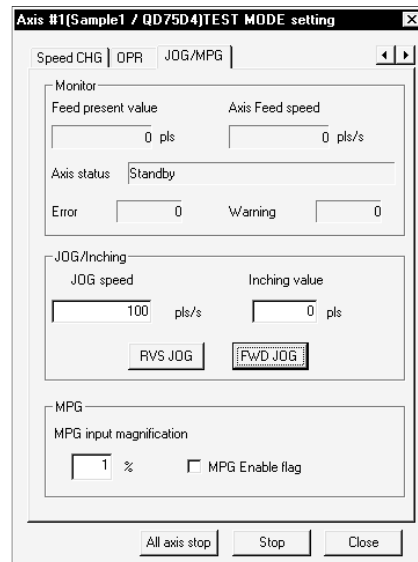



DISPLAY/SETTING DATA

Item	Description
Monitor	Shows the axis status.
JOG speed	Set the speed for JOG operation. You cannot set any value beyond the JOG speed limit. JOG speed is ignored for inching operation.
Inching value	Set the travel amount for inching operation. Set "0" for JOG operation.
"FWD JOG" button "RVS JOG" button	Set the mouse pointer to the required arrow and press the left button of the mouse or press the space key to start JOG operation. <ul style="list-style-type: none"> When inching value is "1" or more Every time you press the button, the pulse equivalent to the inching value is output. Acceleration/deceleration processing is not performed. When inching value is "0" Hold down the left button of the mouse or the space key to continue operation at the specified JOG speed. The travel value increments by one unit (mm, degree, inch, pulse). When the axis motion direction is opposite, change the rotation direction setting in basic parameters 1.
MPG input magnification	Set the multiplying factor per pulse input from the manual pulse generator for MPG operation.
"MPG Enable flag" check box	Check this flag to enable MPG operation in the test mode.
"All axis stop" button	Click this button to stop all axes.
"Stop" button	Click this button to stop the axis.
<<Position start>> tab	Click the tab to show the corresponding test screen.
<<Feed present value CHG>> tab	Positioning start test.....Refer to Section 10.4.1. Present value change testRefer to Section 10.4.2.
<<Speed CHG>> tab	Speed change testRefer to Section 10.4.3.
<<OPR>> tab	OPR test.....Refer to Section 10.4.4.



The inching value is at the given ratio of the JOG speed limit value, and an error will occur if it is greater than the value calculated by the following expression.

- Unit setting of "mm"

$$\text{JOG speed limit value (mm/min)} \times 0.00295 = \text{inching value } (\mu\text{m})$$
- Unit setting of "inch" or "degree"

$$\text{JOG speed limit value (inch/min, degree/min)} \times 0.0000295 = \text{inching value (inch, degree)}$$
- Unit setting of "pulse"

$$\text{JOG speed limit value (pls)} \times 0.00177 = \text{inching value (pls)}$$

11. USEFUL FUNCTIONS

Out of the functions that can be performed on SW□D5C-QD75P-E, this chapter describes the functions and operations useful for project execution, positioning data setting, etc. and the functions which support settings.

This chapter also explains the teaching function which imports the feed present value to the address, the function which writes positioning data in the test mode, the function which prints project setting data, and the trace function which displays operation results as waveform/locus data.

11.1 Useful Functions for Projects

This section describes the functions and operations which are helpful for utilizing project data to create projects and for changing set data.

11.1.1 Verifying the project data

**PURPOSE**

Compare and verify the parameters, positioning data, block start data and condition data of the project set as the active project and the saved project.

**BASIC OPERATION**

1. Set the verify source project as the active project. (Refer to Section 5.2.)
2. Click the [Project] → [Verify Project] menu ().
3. Choose the verify target project in the Verify project dialog box (1) and click the "Verify" button.
4. Set the types and ranges of the data to be verified in the Verify project dialog box (2).
5. Click the "OK" button.
6. Check the results in the Verify result dialog box.

**DISPLAY/SETTING SCREEN**

[Verify project dialog box (1)]

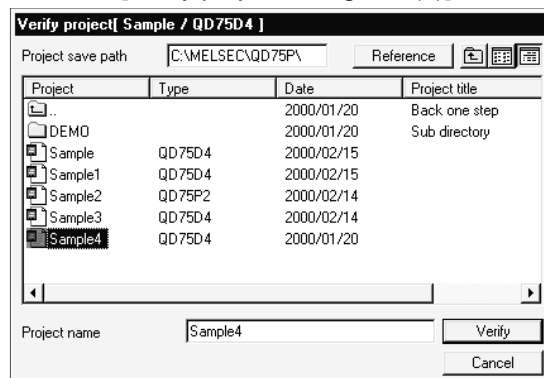

[Verify project dialog box (2)]

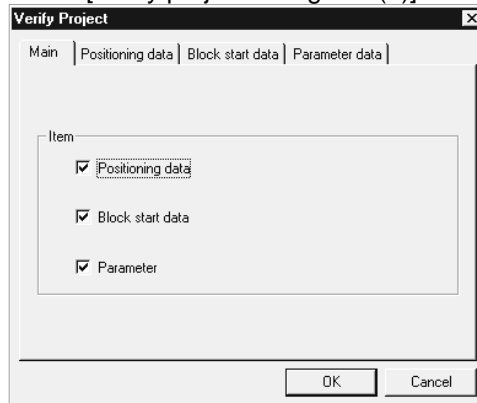

[Verify result dialog box]

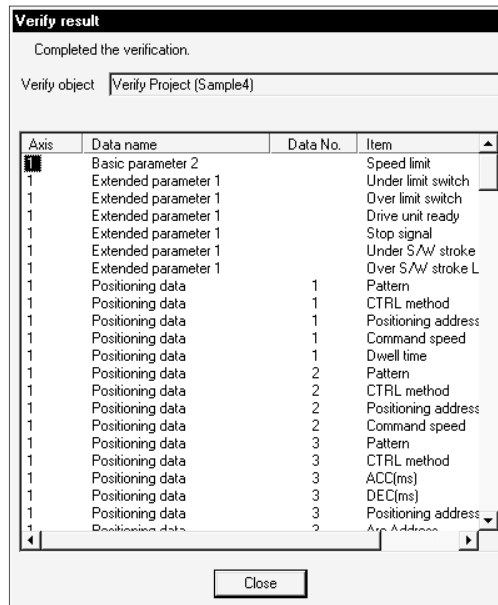

DISPLAY/SETTING DATA

Item	Description
Project name	Click the project name of the verify destination.
Project save path	Shows the project save path of the verify destination.
"Reference" button	Click this button to display the Project tree dialog box (refer to Section 6.1).
"Verify" button	Click this button to show the Verify project dialog box (2).
Verify project dialog box (2)	Set the types and ranges of the data to be verified.
Verify result dialog box	Shows up to 600 different settings between the project set as the active project and the specified project. Verify processing is suspended as soon as the number of mismatches reaches 600.

11.1.2 Changing the QD75 model after data setting



PURPOSE

Change the QD75 model after setting the parameters, positioning data or other data.

If you choose "New QD75 read" in New Project, the model is the same as the QD75 at the read destination. Therefore, when utilizing the data for the other model, change the QD75 model after completion of read.



BASIC OPERATION

1. Set the required project as the active project. (Refer to Section 5.2.)
If in the monitor or test mode, choose the offline status.
2. Click the [Project] → [Change QD75 model] menu.
3. To close the screen being displayed, click the "OK" button in the confirmation dialog box.
4. Choose a new model in the QD75 type select dialog box.
5. Click the "OK" button.



DISPLAY/SETTING SCREEN

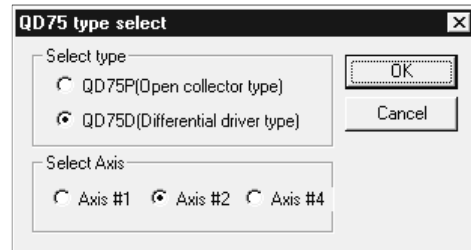

DISPLAY/SETTING DATA

Item	Description
Select type	Choose the model (type with the exception of the axis number) of the QD75.
Select Axis	Choose the number of axes of the QD75.
"OK" button	Click this button to change the model.



Independent of the QD75 model selected for the project, all data that can be set in the edit mode are saved in the project.

In a new project whose number of axes is 1, the parameters, positioning data, block start data, etc. of undisplayed Axis 2 to Axis 4 are saved. (However, the data of Axis 2 to Axis 4 are initial values.)

When the project whose number of axes is 4 is saved after changing to a model for 1 or 2 axes, the data of Axis 3/Axis 4 is saved unchanged.

Therefore, the model can be changed without restriction on the model selected when a new project is created.

11.1.3 Intelligent function utility



PURPOSE

Make setting to read the following data automatically from the QD75 buffer memory to the QCPU devices (e.g. data registers).

The set data are stored in the intelligent function module parameters of the GPPW project.

- Feed present value
- Machine feed value
- Feed speed
- Error No.
- Warning No.
- Enable M code
- Axis operating status

Automatic refresh allows the above data of the QD75 to be imported to the QCPU without creation of a sequence program.



BASIC OPERATION

1. Set the required project as the active project. (Refer to Section 5.2.)
2. Click the [Tool] → [Intelligent function utility] menu.
3. Choose the target GPPW project in the GPPW project dialog box.
4. The intelligent function module utility starts.
5. Set Start I/O No., Package name and Module model name.
6. Click the "Auto refresh" button.
7. Assign the CPU side devices to the automatic refresh items in the Auto refresh setting dialog box.
8. Click the "End setup" button.
9. Click the "Exit" button in the Intelligent function module utility.
10. Click the "Yes" button in the intelligent function module parameter save confirmation dialog box.



DISPLAY/SETTING SCREEN

[GPPW project dialog box]

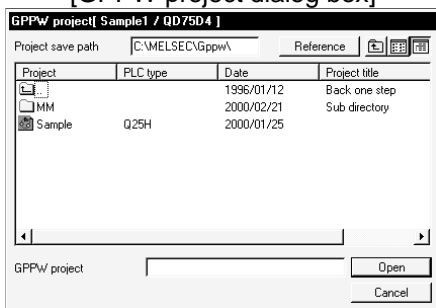

[Intelligent function module utility]

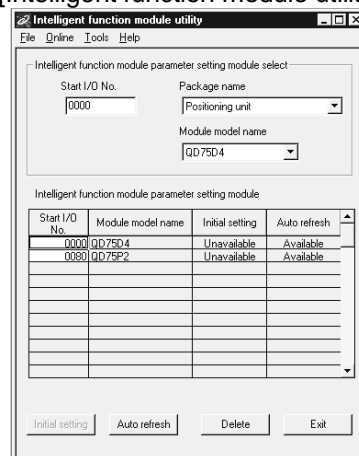

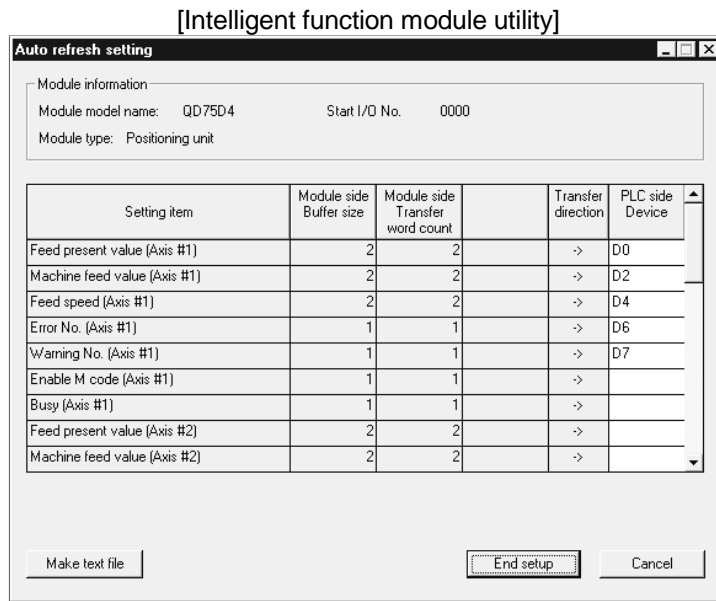

DISPLAY/SETTING DATA

Item	Description
Project save path	Choose the save destination of the GPPW project to which automatic refresh setting will be made.
GPPW project	Choose the GPPW project to which automatic refresh setting will be made.
Start I/O No.	Set the first I/O No. (I/O address) of the QD75.
Package name	Choose the positioning module.
Module model name	Choose the model of the QD75.
Intelligent function module parameter setting module	Shows the module to which the initial setting or automatic refresh setting has been made in the intelligent function module utility.
"Auto refresh" button	Click this button to show the automatic refresh setting dialog box.
"Delete" button	Click this button to make deletion from the intelligent function module parameter setting module.
PLC side device	Set the CPU side devices to be automatically refreshed for the QD75 items. Data is automatically refreshed between the set devices and QD75 buffer memory.
"Make text file" button	Used to save the automatic refresh settings as text data. Clicking this button shows the text file creation dialog box, where you set the save destination drive/path and file name.
"End setup" button	Click this button to register the automatic refresh setting and close the dialog box.



- The CPU side devices set for automatic refresh store the QD75 data. Do not store other values using a sequence program (e.g. FROM and MOV instructions).

11.1.4 Multi-module batch write



PURPOSE

Batch write to multiple QD75s.



- Whether multi-module batch write may be performed or not is determined by the PLC state check setting in Option setting. (Refer to Section 11.5)



BASIC OPERATION

1. Open all projects to be batch written.
2. Specify the connection target in each project. (Refer to Section 7.1.)
3. Click the [Online] → [Writing of batch of multi-module] menu.
4. Choose the project from the project list in the Writing multi-module dialog box, And click the ">>Selected" button.
5. Choose project displayed in the Write project list and click the "Set" button.
6. Set the types and ranges of the data to be written and click the "OK" button.
7. Repeat the above steps 4 to 6 for the projects to be batch written.
8. Click the "Write" button in the Writing multi-module dialog box.



DISPLAY/SETTING SCREEN

[Writing multi-module dialog box]

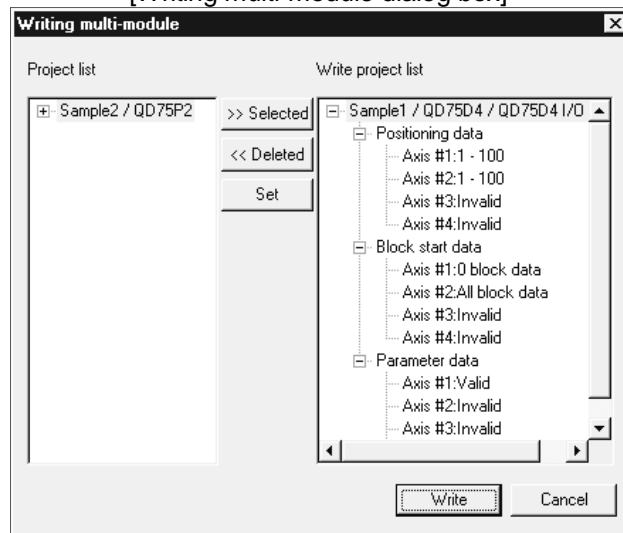

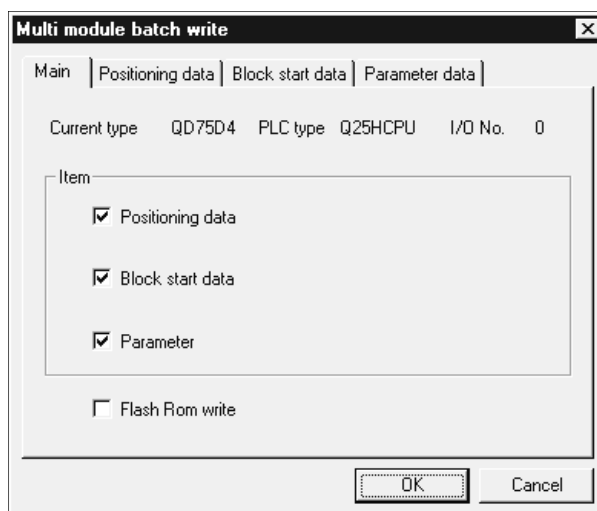

DISPLAY/SETTING DATA

Item	Description
Project list	Shows a list of the projects open in SW□D5C-QD75P-E.
Write project list	Shows the projects for which multi-module batch write will be performed. Make selection from the project list.
">>Selected" button	Click this button to register the project selected on the project list side to the write target project side.
"<<Deleted" button	Click this button to return the project selected on the write target project side to the project list side.
"Set" button	Click this button to show the QD75 write dialog box for the project selected on the write target project side.
<<Main>> <<Positioning data>> <<Block start data>> <<Parameter data>> tab screen	Set the types and ranges of the data to be written to each project. The setting items are the same as in write to QD75. (Refer to Section 9.1.)
"Write" button	Click this button to batch write the projects registered as the write target projects to the QD75.

11.2 Edit Functions for Data Setting

This section explains the edit functions which can be used for positioning data or block start data setting.

11.2.1 Cut/copy/paste

These functions cut/copy and paste some part of the positioning or block start data settings.

Also these functions cut/copy the values entered in Microsoft® Excel® or Word® table and pastes them to the positioning data or block start data of SW□D5C-QD75P-E.

(1) Cut

Used to cut the selected range.

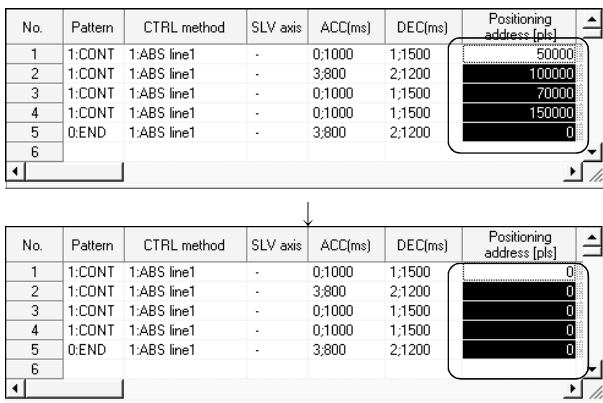

- 1) Choose the area to be cut.
- 2) Click the [Edit] → [Cut] menu ().
Alternatively, click [Cut] in the right-click menu.

- 3) The values in the selected range change to initial values.

(2) Copy

Used to copy the selected range to the clipboard of Microsoft® Windows® Operating System.

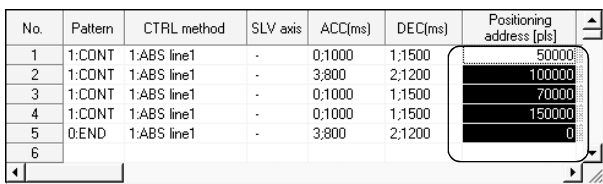

- 1) Choose the area to be copied.
- 2) Click the [Edit] → [Copy] menu ().
Alternatively, click [Copy] in the right-click menu.

(3) Paste

Used to paste the cut or copied data to the selected range.

Note that paste may not be made if:

- The control method is not set to the data of paste destination;
- The data of cut or copy destination is different in control method from the data of paste destination; or
- The item cut or copied is different from the item of paste destination.

No.	Pattern	CTRL method	SLV axis	ACC(ms)	DEC(ms)	Positioning address [pls]
1	1:CONT	1:ABS line1	-	0:1000	1:1500	0
2	1:CONT	1:ABS line1	-	3:800	2:1200	0
3	1:CONT	1:ABS line1	-	0:1000	1:1500	0
4	1:CONT	1:ABS line1	-	0:1000	1:1500	0
5	0:END	1:ABS line1	-	3:800	2:1200	0
6						

1) Choose the paste destination (copy destination) of the data cut (copied).

2) Click the [Edit] → [Paste] menu ().

Alternatively, click [Paste] in the right-click menu.

No.	Pattern	CTRL method	SLV axis	ACC(ms)	DEC(ms)	Positioning address [pls]
1	1:CONT	1:ABS line1	-	0:1000	1:1500	50000
2	1:CONT	1:ABS line1	-	3:800	2:1200	100000
3	1:CONT	1:ABS line1	-	0:1000	1:1500	70000
4	1:CONT	1:ABS line1	-	0:1000	1:1500	150000
5	0:END	1:ABS line1	-	3:800	2:1200	0
6						

3) The values in the selected range change to the cut (copied) data.

(4) Copying and pasting from Microsoft® Excel® / Word® table

Used to copy values entered into the Microsoft® Excel® / Word® table and paste them to positioning data or block start data of SW□D5C-QD75P-E.

[Example of copying Microsoft® Excel® data and pasting them to positioning data]

	A	B
1	12000	
2	21000	
3	24500	
4	30000	
5	19000	
6	52000	
7	44000	
8	39000	
9	17000	
10	12000	



No.	Pattern	CTRL method	SLV axis	ACC(ms)	DEC(ms)	Positioning address [pls]
1	1:CONT	1:ABS line1	-	0:1000	0:1000	12000
2	1:CONT	1:ABS line1	-	0:1000	0:1000	21000
3	1:CONT	1:ABS line1	-	0:1000	0:1000	24500
4	1:CONT	1:ABS line1	-	0:1000	0:1000	30000
5	1:CONT	1:ABS line1	-	0:1000	0:1000	19000
6	1:CONT	1:ABS line1	-	0:1000	0:1000	52000
7	1:CONT	1:ABS line1	-	0:1000	0:1000	44000
8	1:CONT	1:ABS line1	-	0:1000	0:1000	39000
9	1:CONT	1:ABS line1	-	0:1000	0:1000	17000
10	0:END	1:ABS line1	-	0:1000	0:1000	12000
11						
12						
13						

1) Choose and copy the Excel® table.

2) Choose the setting range in the positioning data and click the [Edit] → [Paste] menu ().



HELPFUL OPERATION (1)

When making the same setting for multiple positioning data or block start data, perform the following operation to make batch setting in the selected range. Note that batch setting may be made for the same item (column) only. It cannot be made if you selected multiple items (columns).

1) Choose the batch setting range.

No.	Pattern	CTRL method	SLV axis	ACC(ms)	DEC(ms)
1	1:CONT				
2	1:CONT				
3	1:CONT				
4	1:CONT				
5	0:END				
6					
7					

Example: Batch-set the control method of positioning data No. 1 to 5.

2) Entering the value from the keyboard sets it on the top row of the selected range.

No.	Pattern	CTRL method	SLV axis	ACC(ms)	DEC(ms)
1	1:CONT	1:ABS line1			
2	1:CONT				
3	1:CONT				
4	1:CONT				
5	0:END				
6					
7					

Example: When you type "1", "1:ABS Line 1" appears on the top row of the selected range.

3) Press the Enter key on the keyboard or click the other items with the mouse to change the other rows of the selected range to the same setting.

No.	Pattern	CTRL method	SLV axis	ACC(ms)	DEC(ms)
1	1:CONT	1:ABS line1		0;1000	0;1000
2	1:CONT	1:ABS line1		0;1000	0;1000
3	1:CONT	1:ABS line1		0;1000	0;1000
4	1:CONT	1:ABS line1		0;1000	0;1000
5	0:END	1:ABS line1		0;1000	0;1000
6					
7					

Example: "1:ABS Line 1" is set to all rows of the selected range.



HELPFUL OPERATION (2)

Perform the following operation to cut/copy and paste all ranges of the positioning data or block start data displayed.

1. Click the [Edit] → [Select all] menu.

[Result of clicking [Select all] in the positioning data edit window]

No.	Pattern	CTRL method	SLV axis	ACC(ms)	DEC(ms)	Positioning address [pls]
1	1:CONT	1:ABS line1	-	0;1000	0;1000	40000
2	1:CONT	1:ABS line1	-	0;1000	0;1000	20000
3	1:CONT	1:ABS line1	-	0;1000	0;1000	5000
4	1:CONT	1:ABS line1	-	0;1000	0;1000	10000
5	1:CONT	1:ABS line1	-	0;1000	0;1000	30000
6	1:CONT	1:ABS line1	-	0;1000	0;1000	0
7	1:CONT	1:ABS line1	-	0;1000	0;1000	25000
8	1:CONT	1:ABS line1	-	0;1000	0;1000	45000
9	1:CONT	1:ABS line1	-	0;1000	0;1000	30000
10	1:CONT	1:ABS line1	-	0;1000	0;1000	0
11	1:CONT	1:ABS line1	-	0;1000	0;1000	20000
12	1:CONT	1:ABS line1	-	0;1000	0;1000	5000
13	1:CONT	1:ABS line1	-	0;1000	0;1000	10000
14	1:CONT	1:ABS line1	-	0;1000	0;1000	30000
15	1:CONT	1:ABS line1	-	0;1000	0;1000	0
16	1:CONT	1:ABS line1	-	0;1000	0;1000	25000
17	1:CONT	1:ABS line1	-	0;1000	0;1000	45000
18	1:CONT	1:ABS line1	-	0;1000	0;1000	30000

Point

- When "data No. 1 to data No. 100" has been selected in the data No. setting of the SW D5C-QD75P-E option function, positioning data No. 101 to No. 600 are not included in the selection range.
- For the block start data, only the block to be edited is the selection range
- If data do not match between the axes, data of all ranges cannot be pasted. In that case, perform the axis copy (refer to Section 11.3.1).

11.2.2 Jump



PURPOSE

Move the cursor to the data No. specified for a positioning data edit window. Alternatively, move the cursor to the point No. specified in the block start data edit window.



BASIC OPERATION

1. Click the [Edit] → [Jump] menu.
2. Set the positioning data No. or block start data point No. of the jump destination in the JUMP dialog box.
3. Click the "OK" button.



DISPLAY/SETTING SCREEN

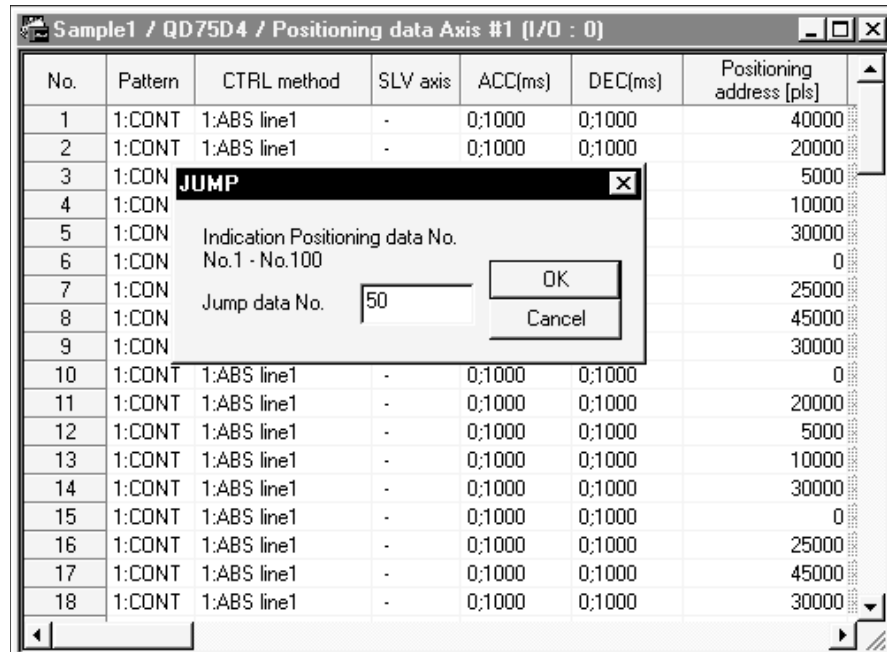

DISPLAY/SETTING DATA

Item	Description
JUMP data	Set the positioning data No. or the block start data point No. of the jump destination.
"OK" button	Click this button to move the cursor to the specified No.

11.2.3 Clearing the rows/columns



PURPOSE

Clear only the rows or columns selected in the positioning data window or block start data edit window.



BASIC OPERATION

1. Choose the rows (columns) which you want to initialize in the positioning data or block start data edit window.
2. Click the [Edit] → [Clear row]/[Clear column] menu.
Alternatively, click the [Clear row]/[Clear column] menu in the right-click menu.

[Example of clearing the rows]

No.	Pattern	CTRL method	SLV axis	ACC(ms)	DEC(ms)	Positioning address [pls]
1	1:CONT	1:ABS line1	-	0;1000	0;1000	40000
2	1:CONT	1:ABS line1	-	0;1000	0;1000	20000
3	1:CONT	1:ABS line1	-	0;1000	0;1000	5000
4						
5						
6						
7	1:CONT	1:ABS line1	-	0;1000	0;1000	25000
8	1:CONT	1:ABS line1	-	0;1000	0;1000	45000
9	1:CONT	1:ABS line1	-	0;1000	0;1000	30000
10	1:CONT	1:ABS line1	-	0;1000	0;1000	0

The selected rows are cleared (to the default values).

[Example of clearing the columns]

No.	Pattern	CTRL method	SLV axis	ACC(ms)	DEC(ms)	Positioning address [pls]
1	1:CONT	1:ABS line1	-	0;1000	0;1000	0
2	1:CONT	1:ABS line1	-	0;1000	0;1000	0
3	1:CONT	1:ABS line1	-	0;1000	0;1000	0
4	1:CONT	1:ABS line1	-	0;1000	0;1000	0
5	1:CONT	1:ABS line1	-	0;1000	0;1000	0
6	1:CONT	1:ABS line1	-	0;1000	0;1000	0
7	1:CONT	1:ABS line1	-	0;1000	0;1000	0
8	1:CONT	1:ABS line1	-	0;1000	0;1000	0
9	1:CONT	1:ABS line1	-	0;1000	0;1000	0
10	1:CONT	1:ABS line1	-	0;1000	0;1000	0

The selected columns are cleared (to the default values).

11.2.4 Initializing the data



PURPOSE

Initialize the parameters, positioning data and block start data (including condition data) of the active project axis-by-axis.

Note that the project data saved in the QD75, HD and FD are not initialized.



BASIC OPERATION

1. Set the project to be initialized as the active project. (Refer to Section 5.2.)
2. Click the [Tool] → [Initialize data] menu.
3. Set the types and axes of the data to be initialized in the Data initialize dialog box.
4. Click the "OK" button.



DISPLAY/SETTING SCREEN

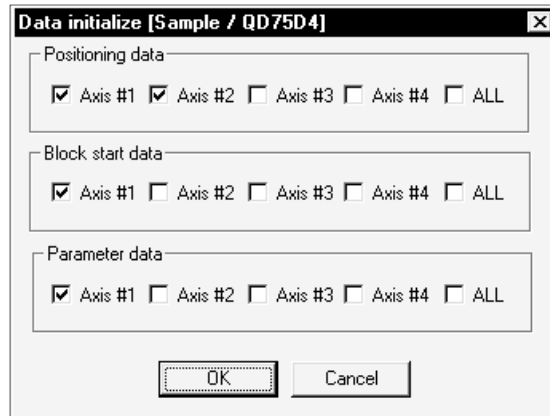

DISPLAY/SETTING DATA

Item	Description
Positioning data	Set the axes of the positioning data to be initialized. Check "ALL" to initialize the positioning data of all axes.
Block start data	Set the axes of the block start data to be initialized. Check "ALL" to initialize the block start data of all axes.
Parameter data	Set the axes of the parameters to be initialized. Check "ALL" to initialize the parameter data of all axes.
"OK" button	Click this button to initialize the data.

11.3 Copying the Data

Copy the positioning data, block start data and parameters set to the project axis-by-axis.

Also, copy the set block start data to another block.

When copying data to another project, use copy/paste of the edit function. (Refer to Section 11.2.1.)

11.3.1 Copying the data on an axis basis (Axis copy)



PURPOSE

Using the axis copy function, copy the positioning data, block start data and parameters of any axis to another axis of the same project.



- When the axis copy is performed, data may not match between the axes. After performing the axis copy, please carry out an error check (refer to Section 8.5).



BASIC OPERATION

1. Display any of the parameters (refer to Section 8.1), positioning data (refer to Section 8.2) and block start data (refer to Section 8.4) edit windows.
2. Click the [Edit] → [Axis copy] menu.
3. Set the axis of the copy source, the types of the data to be copied, and the axis of the copy destination.
4. Click the "OK" button.



DISPLAY/SETTING SCREEN

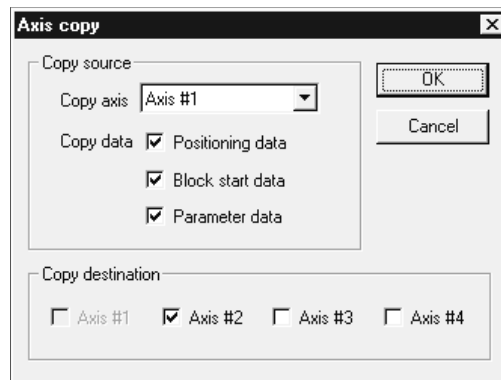

DISPLAY/SETTING DATA

Item	Description
Copy source data	Choose the axis of the copy source and set the data to be copied. The block start data includes condition data.
Copy destination	Set the axis of the copy destination.
"OK" button	Click this button to copy the data.

11.3.2 Block start copy



PURPOSE

Using the block start copy function, copy the block start data to the other blocks. The block start copy function is performed to copy data between blocks in the same project.



BASIC OPERATION

1. Display the block start data edit window (refer to Section 8.4).
2. Click the [Edit] → [Block start copy] menu.
3. Set the block No. of the copy source and the block No. of the copy destination.
4. Click the "OK" button.



DISPLAY/SETTING SCREEN

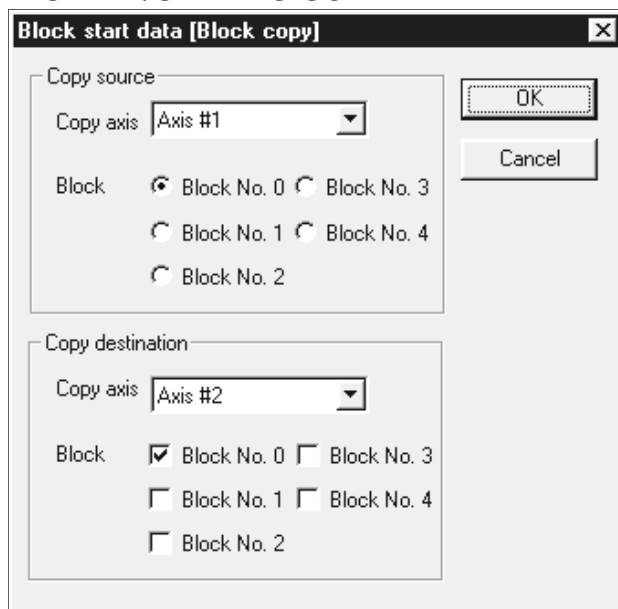

DISPLAY/SETTING DATA

Item	Description
Copy source block No.	Choose the copy axis and the block No. of the copy source.
Copy destination block No.	Set the copy axis and the block No. of the copy destination. Multiple blocks can be set at the same time.
"OK" button	Click this button to copy the data.

11.4 Navigation Function



PURPOSE

Perform the operations necessary to use the QD75, from setting of the parameters and positioning data to write to QD75, monitor and test in the wizard format. For parameter setting data, refer to QD75 User's Manual.



BASIC OPERATION

1. Set the connection target. (Refer to Section 7.1.)
2. Click the [Tool] → [Navigation] menu.
3. When the Navigation function screen appears, perform operation using the following procedure.

If the QD75 is not loaded, steps 4) to 10) cannot be executed.

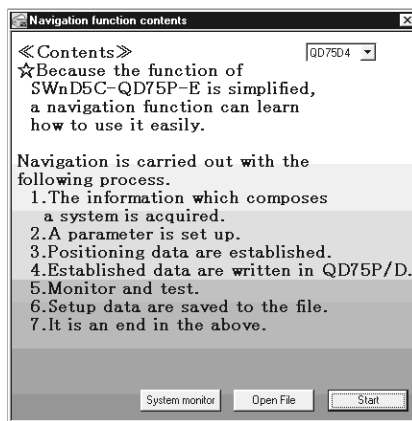

1) Choose the QD75 model.

2) Click the "Start" button.

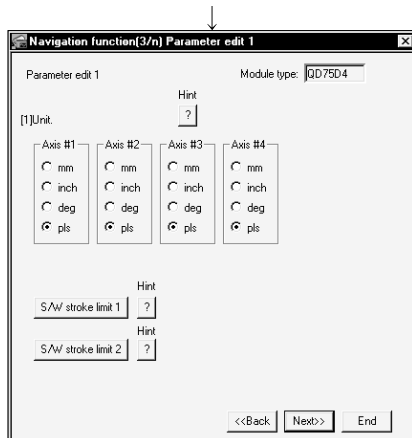

3) Make setting on the parameter edit 1 screen. After setting, click the "Next>>" button.

Clicking the button shows the hint for the corresponding item.

Set each parameter.
(Screen is eliminated for simplicity)

* To change the setting, click the "<<Back" button to return to the preceding screen.

(To the next page)

(From the preceding page)

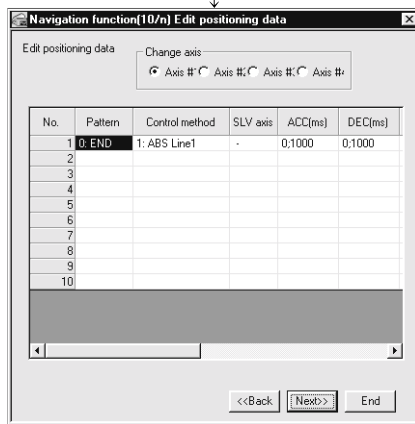

- 4) Choose the axis in Change axis and set the positioning data.
After setting, click the "Next>>" button.

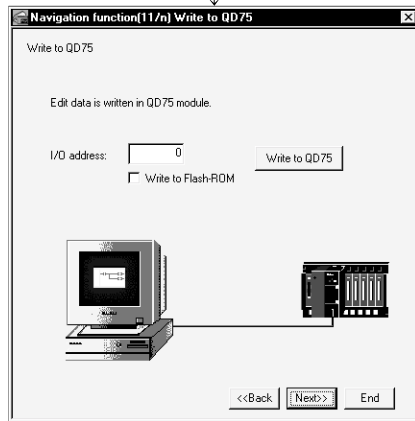

- 5) Set I/O address
To write data to the flash ROM of the QD75 at the same time, click unchecked "Write to flash ROM".

- 6) Click the "Write to QD75" button.
When write is completed, click the "Next>>" button.

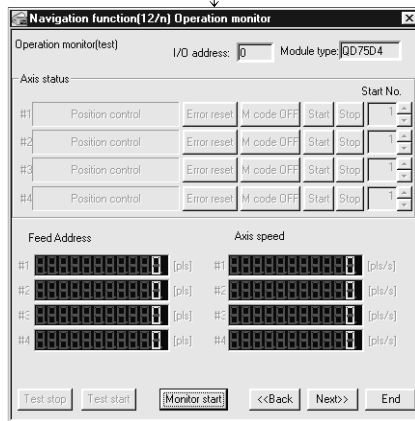

- 7) Click the "Monitor start" button.
- 8) Click the "Test start" button.

(To the next page)

(From the preceding page)

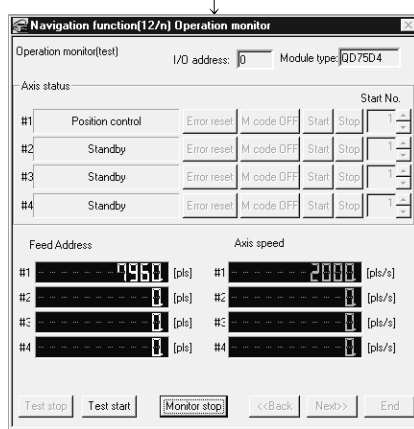

- 9) Set the positioning data No. in Start and click the "Start" button to start test operation. Use the "Stop", "Error reset" and/or "M code OFF" button as necessary.
- 10) When the test is over, click the "Test stop" button. After exiting from the test mode, click the "Next>>" button.



- 11) When saving the set parameters and positioning data, click the "Save as project" button. When not saving them, click the "End" button.

11.5 Option Setting

**PURPOSE**

Set the option function of SW□D5C-QD75P-E.

The option function is used to make settings for write to QD75 and set the display range of positioning data.

**BASIC OPERATION**

1. Click the [Tool] → [Option] menu.
2. Make settings in the Option settings dialog box.
3. To exit, click the "OK" button.

**DISPLAY/SETTING SCREEN**

The screenshot shows the 'Option setting' dialog box with the following settings:

- Flush-Rom write: Yes, No
- Write data enable flag: Write data enable
- Positioning data set: Data No.1 to Data No.100, Range (1 - 600)
- PLC state check: PLC state check (The state of STOP is confirmed)

Buttons: OK, Cancel



DISPLAY/SETTING DATA

Item	Description																																				
Flash ROM write	Select whether data will be written to flash ROM or not in the initial setting for write to QD75. • YES Choose Yes to make the initial setting that data will be written to flash ROM when write to QD75 is performed. • NO Choose No to make the initial setting that data will not be written to flash ROM when write to QD75 is performed.																																				
Write data enable flag	When you check this check box, any changes in the test mode using positioning data test edit or teaching are retained after the end of the test mode. When you do not check this check box, data changes in the test mode are made invalid and return to the previous data at the end of the test mode.																																				
Positioning data set	Choose the range of the positioning data No. to be displayed on the positioning data edit window. • Data No. 1 to No. 100 Shows positioning data No. 1 to 100. • Range Shows positioning data No. 1 to 600.																																				
PLC state check	Make selection whether the PLC state is checked or not when write to QD75, multi-module batch write, flash ROM write request or QD75 initialization is executed. (Default is "checked") Since the set data on the Option screen is saved not on a project basis but on an application basis, the selected set values apply to all projects. If you do not choose PLC state check, write cannot be performed when X0 (QD75 ready signal) of the corresponding module is ON. <table border="1" data-bbox="485 965 1409 1189" style="margin: 10px auto;"> <thead> <tr> <th data-bbox="485 965 667 994">PLC state check</th> <th colspan="4" data-bbox="667 965 855 994"><input checked="" type="checkbox"/> PLC state check</th> <th colspan="4" data-bbox="855 965 1409 994"><input type="checkbox"/> PLC state check</th> </tr> <tr> <th data-bbox="485 994 667 1023">PLC state</th> <th colspan="2" data-bbox="667 994 762 1023">STOP</th> <th colspan="2" data-bbox="762 994 855 1023">except STOP</th> <th colspan="2" data-bbox="855 994 967 1023">STOP</th> <th colspan="2" data-bbox="967 994 1409 1023">except STOP</th> </tr> </thead> <tbody> <tr> <td data-bbox="485 1023 667 1122">X0 status of corresponding module</td> <td data-bbox="667 1023 762 1122">ON</td> <td data-bbox="762 1023 855 1122">OFF</td> <td data-bbox="855 1023 951 1122">ON</td> <td data-bbox="951 1023 1046 1122">OFF</td> <td data-bbox="1046 1023 1142 1122">ON</td> <td data-bbox="1142 1023 1238 1122">OFF</td> <td data-bbox="1238 1023 1334 1122">ON</td> <td data-bbox="1334 1023 1409 1122">OFF</td> </tr> <tr> <td data-bbox="485 1122 667 1189">Write processing</td> <td data-bbox="667 1122 762 1189">× (Note 2)</td> <td data-bbox="762 1122 855 1189">○</td> <td data-bbox="855 1122 951 1189">× (Note 1)</td> <td data-bbox="951 1122 1046 1189">× (Note 1)</td> <td data-bbox="1046 1122 1142 1189">× (Note 2)</td> <td data-bbox="1142 1122 1238 1189">○</td> <td data-bbox="1238 1122 1334 1189">× (Note 2)</td> <td data-bbox="1334 1122 1409 1189">○</td> </tr> </tbody> </table> <p style="text-align: right; margin-right: 20px;">○ : Write enabled × : Write disabled</p> <p>Note 1 : "Please make the status of PLC in to STOP or remove the check on the PLC state check on the option screen. " appears.</p> <p>Note 2 : "The QD75 READY signal is turned on. Please execute again after turning off the QD75 READY signal." appears.</p>	PLC state check	<input checked="" type="checkbox"/> PLC state check				<input type="checkbox"/> PLC state check				PLC state	STOP		except STOP		STOP		except STOP		X0 status of corresponding module	ON	OFF	ON	OFF	ON	OFF	ON	OFF	Write processing	× (Note 2)	○	× (Note 1)	× (Note 1)	× (Note 2)	○	× (Note 2)	○
PLC state check	<input checked="" type="checkbox"/> PLC state check				<input type="checkbox"/> PLC state check																																
PLC state	STOP		except STOP		STOP		except STOP																														
X0 status of corresponding module	ON	OFF	ON	OFF	ON	OFF	ON	OFF																													
Write processing	× (Note 2)	○	× (Note 1)	× (Note 1)	× (Note 2)	○	× (Note 2)	○																													
"OK" button	Click this button to determine the set data.																																				



When you increased the display range in positioning data display No. setting, it will take longer until the positioning data edit window appears.
 When positioning data No. 101 onwards are not necessary, choose data No. 1 to No. 100. (The positioning data No. defaults to data No. 1 to No. 100.)

11.6 Printing the Project Data

Print the positioning data, block start data and parameters set in the project.

11.6.1 Printer setting

**PURPOSE**

Choose the printer connected to the peripheral device, paper and printing orientation.

For printer setting, refer to Microsoft® Windows® Operating System manual. Also, for the printer properties, refer to the printer manual as they depend on Microsoft® Windows® Operating System manual printer driver used.

**BASIC OPERATION**

1. Click the [Project] → [Printer setup] menu.
2. Set the printer, etc.
3. To exit, click the "OK" button.

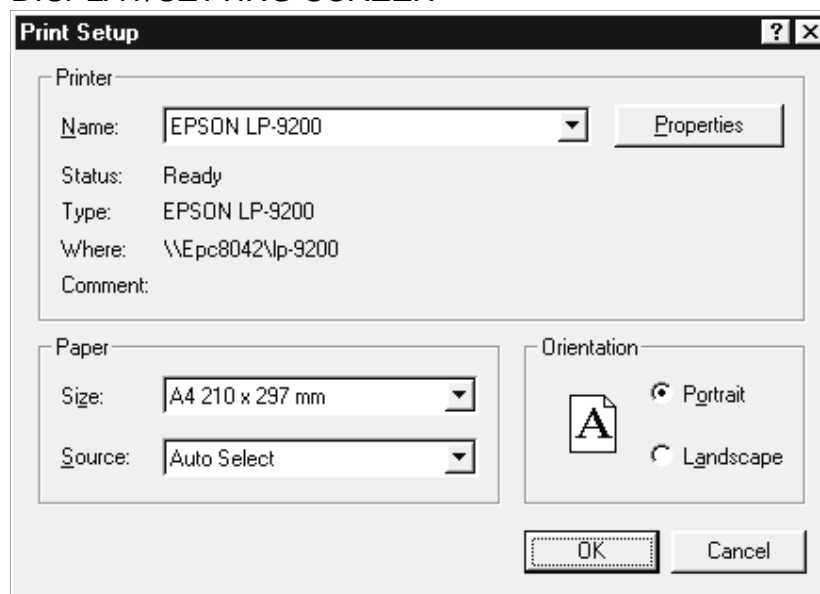
**DISPLAY/SETTING SCREEN**

(The screen shows the setting for Windows® 95.)

11.6.2 Printing



PURPOSE

Print the positioning data, block start data (including condition data) and parameter data of the active project.



BASIC OPERATION

1. Set the project to be printed as the active project. (Refer to Section 5.2.)
2. Click the [Project] → [Print] menu ().
3. Set the axes and data types and ranges to be printed.
4. Click the "Print preview" button.
5. Clicking the "Print" button shows the Print dialog box.
6. Click the "OK" button in the Print dialog box to start printing.



DISPLAY/SETTING SCREEN

<<Item specification>> tab screen

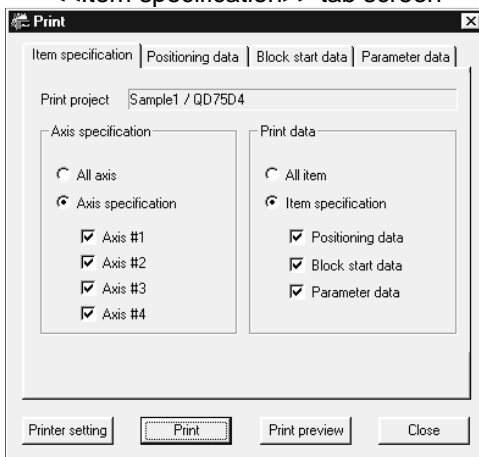

<<Positioning data>> tab screen

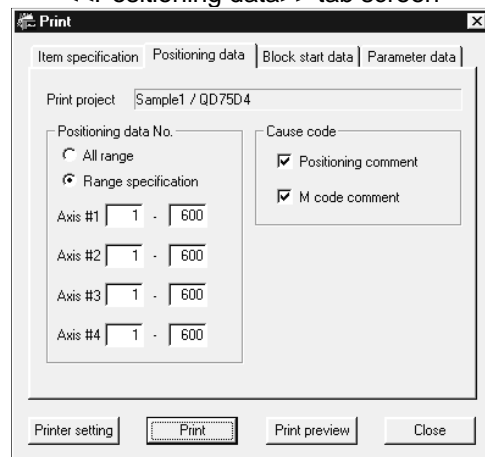

<<Block start data>> tab screen

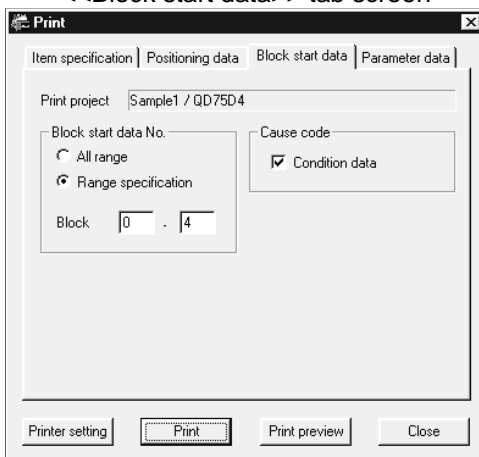

<<Parameter data>> tab screen

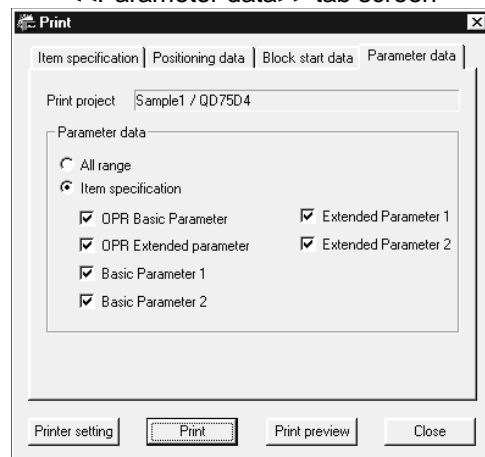

[Print preview screen]

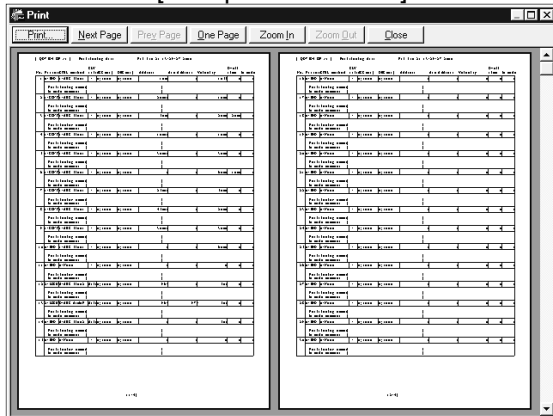

[Print dialog box]

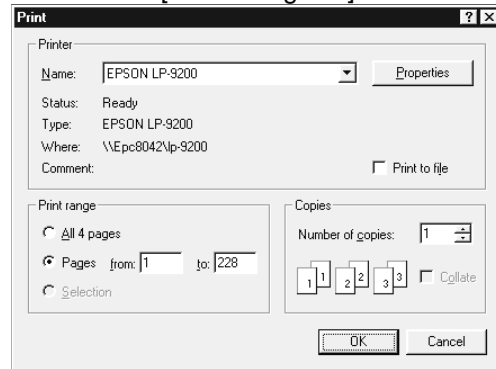

DISPLAY/SETTING DATA

Item	Description
Print project	Shows the project name to be printed. The project selected on the project tree view is to be printed.
Axis specification	Set the axes whose data will be printed.
Print data	Set the types of data to be printed.
Positioning data No.	Set the printing ranges of positioning data. You can add positioning data and M code comments as additional information.
Block start data No.	Set the printing range of block start data. You can add condition data as additional information.
Parameter data	Set the parameter types to be printed.
"Printer setting" button	Click this button to display the Print setting dialog box (refer to Section 11.6.1).
"Print" button	Click this button to show the Print dialog.
"Print preview" button	Click this button to display the Print preview.
"Next Page" button "Prev Page" button	Click the corresponding button to preview the next or previous page.
"One Page/Two Page" button	Click this button to switch the preview between 1 page display and 2 page display.
"Zoom In" button "Zoom Out" button	Click the "Zoom In" button to enlarge the preview display. Click the "Zoom Out" button to reduce the preview display.
Printer Name	Select the printer name.
"Properties" button	Click this button to display the printer property dialog box. For the printer properties, refer to the printer manual.
Print range	Set the range of printing.
Copies	Set the number of copies printed.
"OK" button	Click this button to start printing.

[Positioning data print example]

[QD75D4 #1] Positioning data Wed Mar 01 09:57:13 2000										
No.	Pattern	CTRL method	SLV axis	ACC	DEC	Address	Arc Address	Speed	Dwell time	M code
1	2:LOCUS	D:ABS ArcMP	#2	0;1000	0;1000	0	250	1000	500	0
	Positioning comment [Center] M code comment []									
2	2:LOCUS	D:ABS ArcMP	#2	0;1000	0;1000	1000	500	1000	0	1
	Positioning comment [Point1] M code comment [Paint]									
3	2:LOCUS	D:ABS ArcMP	#2	0;1000	0;1000	0	500	1000	500	0
	Positioning comment [Center] M code comment []									
4	2:LOCUS	D:ABS ArcMP	#2	0;1000	0;1000	0	250	1000	0	1
	Positioning comment [Point2] M code comment [Paint]									

[Block start data print example]

[QD75D4 #1] Block start data (Block No.0) Wed Mar 01 09:53:01 2000			
No.	Pattern	Data No.	Special start Param Condition data
1	1:CONT	1	1:COND start 1 (800) <= (99999)
2	1:CONT	10	2:Wait start 2 (800) => (100000)
3	1:CONT	20	3:SIMU start 3 Axis #2(No.50),Axis #3(No.50)
4	1:CONT	30	4:FOR loop 0 Repeat count
5	1:CONT	40	6:NEXT start 0
6	0:END	0	0:Normal start 0
7	0:END	0	0:Normal start 0
8	0:END	0	0:Normal start 0
9	0:END	0	0:Normal start 0
10	0:END	0	0:Normal start 0

[Parameter print example]

[QD75D4 #1] Parameter data Basic Parameter 1 Wed Mar 01 09:54:01 2000			
No.	Parameter name	Data set range	Data
1	Unit	0:mm 1:inch	2:degree 3:pulse 3
2	Pulse per rotation	1 - 65535 pls	20000 pls
3	Travel per rotation	1 - 65535 pls	20000 pls
4	Unit multiplier	1: 1 times 10: 10 times	100: 100 times 1000: 1000 times 1
5	Pulse output mode	0:PLS/SIG mode 1:CW/CCW mode	2:A/B mode(4) 3:A/B mode(1) 1

11.7 Positioning Data Setting in Test Mode

In the test mode, import the feed address to the positioning data address and write changed positioning data to the QD75.

11.7.1 Teaching

**PURPOSE**

Enter the feed address of the axis moved by JOG or MPG operation into the address of the positioning data.

**BASIC OPERATION**

1. Click unchecked Write data enable flag in Option. (Refer to Section 11.5.)
2. Click the [Online] → [Test] → [Test On/Off] menu ().
3. The positioning data edit window appears. (Refer to Section 8.2.1)
4. Clicking the [Online] → [Test] → [Teaching] menu () shows the feed address in the Teaching dialog box.
5. Click the [Online] → [Test] → [Operation test] → [Operation test #1 to #4] menu (to).
6. Click the <<JOG/MPG>> tab in the TEST MODE setting dialog box.
7. Perform JOG or MPG operation to move the axis. (Refer to Section 10.4.5.)
8. Clicking the "Update" button in the Teaching dialog box displays the latest feed address.
9. In the positioning data monitor window, choose the positioning data No. address or arc address where the feed address will be imported.
10. Clicking the "Teaching" button enters the feed address to the positioning data No. address or arc address.
11. Repeat the basic operation steps 7 to 10 to continue teaching.
12. To end teaching, click the [Online] → [Test] → [Teaching] menu ().



- If the Write data enable flag in Option is not made valid, the peripheral device does not retain the address set in the test mode.
Make the Write data enable flag invalid when you do not change the positioning data in the peripheral device.



DISPLAY/SETTING SCREEN

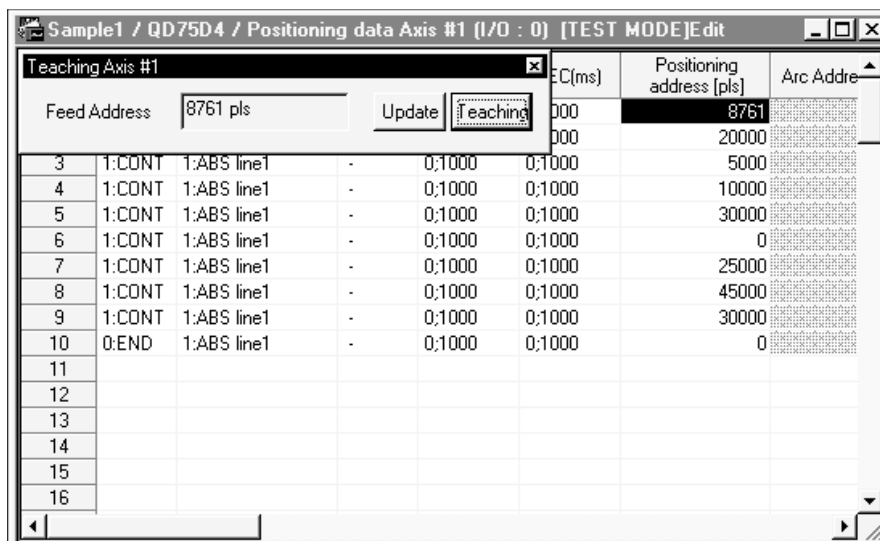

DISPLAY/SETTING DATA

Item	Description
Feed Address	Shows the feed address of the QD75.
"Update" button	Click this button to update the "feed address" to the latest feed address.
"Teaching" button	Click this button to enter the "feed address" into the cell selected in the positioning data edit window.
Positioning data edit window	Screen used to perform teaching or positioning data test edit in the test mode. Double-clicking the address or arc address influences the feed address.

11.7.2 Positioning data test edit



PURPOSE

Change the positioning data or block start data in the test mode and write them to the QD75.



BASIC OPERATION

1. Click unchecked Write data enable flag in Option. (Refer to Section 11.5.)
2. Click the [Online] → [Test] → [Test On/Off] menu ().
3. The positioning data/block start data edit window appears. (Refer to Section 8.2.1/Section 8.4.1.)
4. Click the [Online] → [Test] → [Edit positioning data] menu ().
5. Edit the positioning data/block start data. (Refer to Section 8.2.1. / 8.4.1.)
6. Clicking the [Online] → [Test] → [Edit positioning data] menu () shows the dialog box which confirms whether to write the edited data to the QD75 or not.
7. Click the "OK" button to write to the QD75 the positioning data or block start data changed in the test mode.

When you click [Cancel], write to QD75 is not performed.



- If the Write data enable flag in Option is not made valid, the data changed or set in the test mode are not retained.
Make the Write data enable flag invalid when you do not change the positioning data on the peripheral device.



DISPLAY/SETTING SCREEN

No.	Pattern	CTRL method	SLV axis	ACC(ms)	DEC(ms)	Positioning address [pls]	Arc Address
1	1:CONT	1:ABS line1	-	0;1000	0;1000	40000	
2	1:CONT	1:ABS line1	-	0;1000	0;1000	20000	
3	1:CONT	1:ABS line1	-	0;1000	0;1000	5000	
4	1:CONT	1:ABS line1	-	0;1000	0;1000	10000	
5	1:CONT	1:ABS line1	-	0;1000	0;1000	30000	
6	1:CONT	1:ABS line1	-	0;1000	0;1000	0	
7	1:CONT	1:ABS line1	-	0;1000	0;1000	25000	
8	1:CONT	1:ABS line1	-	0;1000	0;1000	45000	
9	1:CONT	1:ABS line1	-	0;1000	0;1000	30000	
10	0:END	1:ABS line1	-	0;1000	0;1000	0	
11							
12							
13							
14							
15							
16							

The data changed in the test mode are shown in green letters.

11.8 Wave Trace

Using the wave trace function in the trace mode, show the speed command (axis speed) for positioning operation as waveform data.

11.8.1 Wave trace condition setting



PURPOSE

To execute the wave trace, set the trace starting condition and the data to be traced.



BASIC OPERATION

1. Choose Wave trace.

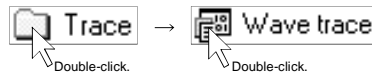

2. Click the "Setting" button in the wave trace window.
3. Set the Trace interval, Trace trigger, Stop condition, axis and data to be traced in the Trace setting dialog box.
4. Click the "OK" button in the Trace setting dialog box.
5. For the tracing operation that follows, refer to Section 11.8.2.



DISPLAY/SETTING SCREEN

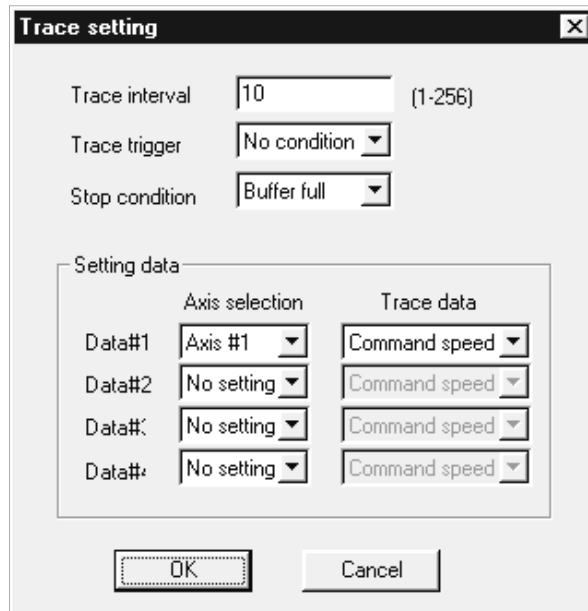



DISPLAY/SETTING DATA

Item	Description
Trace interval	Set the trace interval within the range 1 to 256. The interval is the set value \times 1.77ms.
Trace trigger	Choose the actual trace starting condition. <ul style="list-style-type: none"> • No condition Trace starts at the start request of the peripheral device. • Wait start Trace actually starts when the start signal (X10/X11/X12/X13) turns on after the start request from the peripheral device.
Stop condition	Choose the trace stopping condition. <ul style="list-style-type: none"> • Buffer full Trace stops when the trace data area becomes full. • Endless Trace stops at the stop request of the peripheral device. • Error stop Trace stops when an error occurs. • Trace point Trace stops when the number of trace points reaches the specified value (1 to 8192).
Data #1 Data #2 Data #3 Data #4	Represents the trace data No.
Axis selection	Choose the axis whose data will be traced.
Trace data	Choose the data type to be traced. <ul style="list-style-type: none"> • Command speed Waveform data of the feed speed from the QD75 to the servo amplifier.
"OK" button	Click this button to close the Trace setting dialog box and display the axis number and data type in the wave trace window.

11.8.2 Wave trace execution



PURPOSE

Execute wave trace after setting the trace conditions in accordance with Section 11.8.1.



BASIC OPERATION

1. Perform the basic operation in Section 11.8.1 to set the trace conditions.
2. Click the "Trace" button to initialize the QD75.
3. When initialization is completed, click the "Start" button in the dialog box.
4. The trace data is read when the trace stop type condition is satisfied or the "Stop" button is clicked.
5. Check the QD75 control results from the displayed trace results.



DISPLAY/SETTING SCREEN

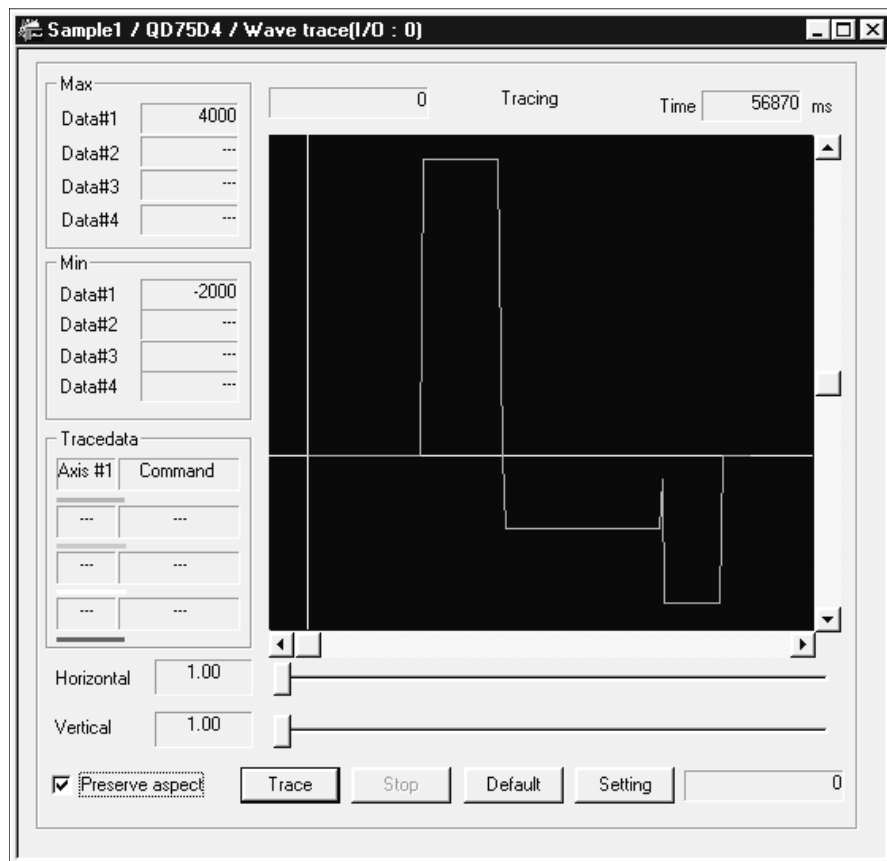



DISPLAY/SETTING DATA

Item	Description
Max Min	Show the maximum and minimum values during tracing of each data.
Time	Shows the tracing time.
Waveform data	Shows the trace results. The horizontal axis indicates time. The vertical axis represents the value of the traced data. Use the scroll bars to move the display position.
Horizontal Vertical	Show the display multiplying factor of the locus data. Move  to the right to enlarge or to the left to reduce.
Preserve aspect	Check this check box to make the locus data display multiplying factor equal in the vertical and horizontal directions.
Trace data	Shows the axes and data types set in the Trace setting dialog box.
"Trace" button	Click this button to initialize the QD75. On completion of initialization, the "Start" button in the dialog box is made valid. Clicking the "Start" button gives a trace start request to the QD75. If the trigger condition is "No condition", trace starts. If the trigger condition is other than "No condition", trace actually starts when the trigger condition holds.
"Stop" button	Click this button to stop trace and show the trace results. If the stop condition is Buffer full, Error stop or Trace point, clicking the "Stop" button stops trace and shows the trace results available at that point.
"Default" button	Click this button to update the display to the latest trace data.
"Setting" button	Click this button to display the Trace condition dialog box.



HELPFUL OPERATION

Clicking the [Project] → [Export file] → [File writing of Trace data] menu saves the trace data and trace conditions.

To read the trace data file, perform the following operation.

1. Using Change QD75 model (refer to Section 11.1.2), choose the same model as the one at the time of write.
2. Display the wave trace window.
3. Click the [Project] → [Import file] → [File reading of Trace data] menu.
4. Click the "OK" button in the on-screen trace data overwrite confirmation dialog box.
5. Choose the file location and file name in the file opening dialog box and click the "Open" button to show the saved waveform data and trace conditions.



- The locus trace file cannot be read during wave trace.

11.9 Locus Trace

Using the locus trace function in the trace mode, show 2-axis interpolation control or simultaneous start (2 axes) as locus data.

11.9.1 Locus trace condition setting



PURPOSE

To execute the locus trace, set the trace starting condition and the data to be traced.



BASIC OPERATION

1. Choose Locus trace.

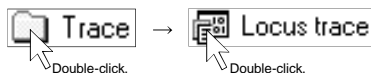

2. Click the "Setting" button in the locus trace window.
3. Set the Trace trigger, Stop condition, and axis and data to be traced in the Trace setting dialog box.
4. Click the "OK" button in the Trace setting dialog box.
5. For the tracing operation that follows, refer to Section 11.9.2.



DISPLAY/SETTING SCREEN

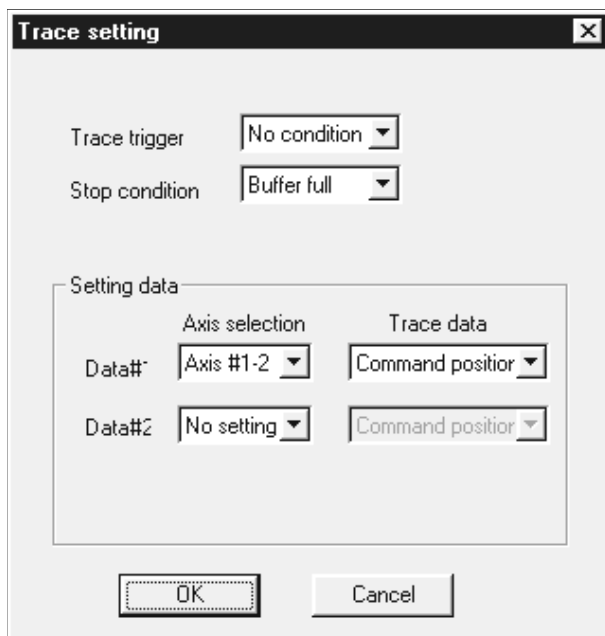



DISPLAY/SETTING DATA

Item	Description
Trace trigger	Choose the actual trace starting condition. <ul style="list-style-type: none"> • No condition Trace starts at the start request of the peripheral device. • Wait start Trace actually starts when the start signal (X10/X11/X12/X13) turns on after the start request from the peripheral device.
Stop condition	Choose the trace stopping condition. <ul style="list-style-type: none"> • Buffer full Trace stops when the trace data area becomes full. • Endless Trace stops at the stop request of the peripheral device. • Error stop Trace stops when an error occurs. • Trace point Trace stops when the number of trace points reaches the specified value (1 to 8192).
Data #1 Data #2	Represents the trace data No.
Axis selection	Choose the combination of the axes whose data will be traced. In the locus data of the trace results, the first axis number is for the horizontal axis and the latter axis number is for the vertical axis. When you selected "#1-#4", #1 is for the horizontal axis and #4 for the vertical axis.
Trace data	Choose the data type to be traced. <ul style="list-style-type: none"> • Position command Locus data of the feed address from the QD75 to the servo amplifier.
"OK" button	Click this button to close the Trace setting dialog box and display the axis numbers and data types in the locus trace window.

11.9.2 Locus trace execution



PURPOSE

Execute locus trace after setting the trace conditions in accordance with Section 11.9.1.



BASIC OPERATION

1. Perform the basic operation in Section 11.9.1 to set the trace conditions.
2. Click the "Trace" button to initialize the QD75.
3. When initialization is completed, click the "Start" button in the dialog box.
4. The trace data is read when the trace stop type condition is satisfied or the "Stop" button is clicked.
5. Check the QD75 control results from the displayed trace results.



DISPLAY/SETTING SCREEN

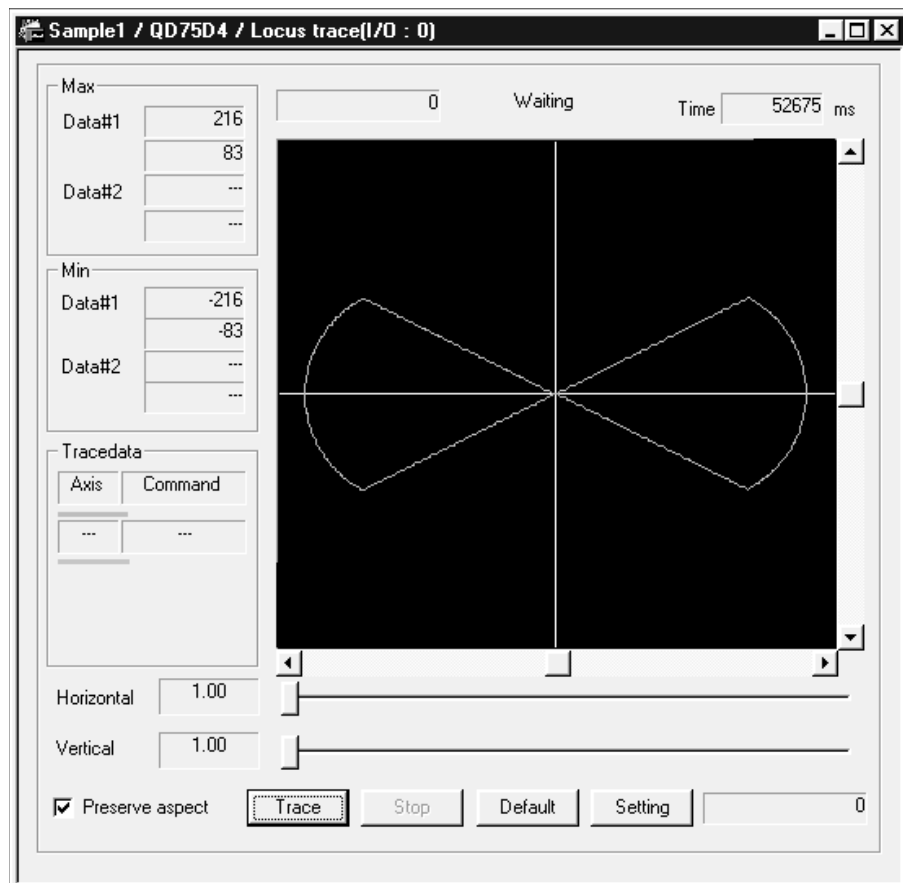



DISPLAY/SETTING DATA

Item	Description
Max Min	Show the maximum and minimum values during tracing of each data.
Time	Shows the tracing time.
Locus data	Shows the trace results. The horizontal and vertical axes indicate the respective addresses (travel distances) of the axis numbers set in trace condition setting. (When #1-#2 is selected as the axis number to be traced, the horizontal axis is Axis #1 and the vertical axis is Axis #2.) Use the scroll bars to move the display position.
Horizontal Vertical	Show the display multiplying factor of the locus data. Move  to the right to enlarge or to the left to reduce.
Preserve aspect	Check this check box to make the locus data display multiplying factor equal in the vertical and horizontal directions.
Trace data	Shows the axes and data types set in the Trace setting dialog box.
"Trace" button	Click this button to initialize the QD75. On completion of initialization, the "Start" button in the dialog box is made valid. Clicking the "Start" button gives a trace start request to the QD75. If the trigger condition is "No condition", trace starts. If the trigger condition is "Wait start", trace actually starts when the trigger condition holds.
"Stop" button	Click this button to stop trace and show the trace results. If the stop condition is Buffer full, Error stop or Trace point, clicking the "Stop" button stops trace and shows the trace results available at that point.
"Default" button	Click this button to update the display to the latest trace data.
"Setting" button	Click this button to display the Trace condition dialog box.



HELPFUL OPERATION

Clicking the [Project] → [Export file] → [File writing of Trace data] menu saves the trace data and trace conditions.

To read the trace data file, perform the following operation.

1. Using Change QD75 model (refer to Section 11.1.2), choose the same model as the one at the time of write.
2. Display the locus trace window.
3. Click the [Project] → [Import file] → [File reading of Trace data] menu.
4. Click the "OK" button in the on-screen trace data overwrite confirmation dialog box.
5. Choose the file location and file name in the file opening dialog box and click the "Open" button to show the saved locus data and trace conditions.



- The locus trace file cannot be read during wave trace.

11.10 Help



PURPOSE

With the help function, you can check the following.

- Error code List
- Warning code List
- I/O signals
- Buffer memory address List



BASIC OPERATION

1. Click the [Help] → [Error/Warning/List of Buffer memory] menu.



DISPLAY/SETTING SCREEN

[Help]

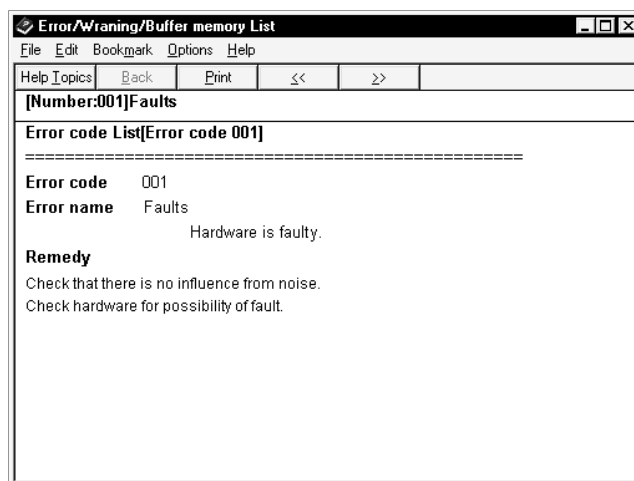
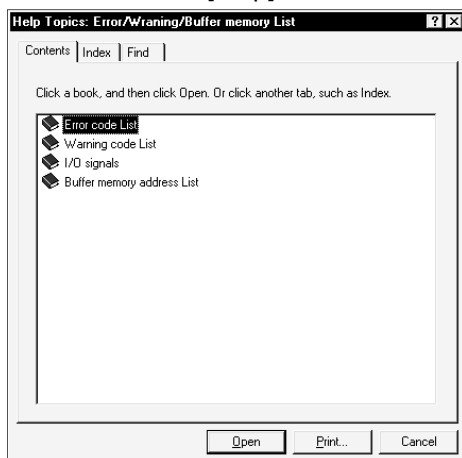

APPENDIX

APPENDIX 1 QD75 READ/WRITE REFERENCE PROCESSING TIMES

The following table indicates the reference times required for read/write processing from SW□D5C-QD75P-E to QD75. Read/write should be performed in the following environment.

	Item	Description
Peripheral device	CPU	Pentium® 166MHz, Microsoft® WindowsNT® Workstation 4.0 Operating System
	Memory	64MB
	Interface	Serial port
	Transfer speed	9600bps, 19200bps, 115200bps
Read/write data	Positioning data	Axis #1 to #4: No. 1 to 600 each
	Block start data	Axis #1 to #4: Block No. 0 to 4 each
	Parameters	Axis #1 to #4

- Write (QCPU direct connection)

Transfer speed 9600bps : 1 minute 31 seconds (1 minute 51 seconds)
 19200bps : 1 minute 2 seconds (1 minute 4 seconds)
 115200bps : 18 seconds (22 seconds)

- Read (QCPU direct connection)

Transfer speed 9600bps : 1 minute 32 seconds (1 minute 52 seconds)
 19200bps : 1 minute 3 seconds (1 minute 5 seconds)
 115200bps : 18 seconds (21 seconds)

INDEX

[2]

- 2-axis interpolation control
 - assisting the setting of 8- 6
 - simulation of 8-10
 - trace of 11-33

[A]

- active project
5- 2, 6- 7, 12, 13, 9- 1, 4, 10-21,11-1, 3, 4, 14, 23
- all axis stop 10- 1
- application
 - ending 4-11
 - starting 4-10
- assistance
 - setting axis speed 8- 7
 - storing buffer memory values 11- 4
- Axis #1 to #4
 - error reset of 7- 6, 7, 10- 1
 - turning off the M code ON signal of 10- 1
- axis control monitor 10-11
- axis copy 11-15
- axis status 7- 4, 10- 4

[B]

- batch write 11- 6
- baud rate 7- 1
- block
 - copy 11-16
 - switching 5- 1, 8-12
- block start data
 - error (project) 8-16
 - error (QD75) 10- 2
 - initialization 11-14
 - setting 8-12
- buffer memory
 - assigning to devices 11- 4
 - list 11-37

[C]

- cable 2- 3, 7- 3
- check box 5- 3
- column clear 11-13
- COM port setting 7- 1
- command button 5- 3

- comment
 - M code 8- 8
 - positioning data 8- 5
- condition
 - of special start 8- 13
 - of trace start 11-31, 35
- condition data 8- 13, 14
- connection setup 7- 1
- copy
 - of block start data 11-16
 - of selection range 11- 8
 - on axis basis 11-15
- CPU
 - corresponding 1- 1
 - storing buffer memory values into 11- 4
 - type of 7- 2
- CSV format positioning data file
 - reading of 6-12
 - writing of 6-13
- cut 11- 8

[D]

- data initialization 11-14
- deletion
 - of project 6- 8
 - of software package 4- 6
- display
 - of status bar 5- 1
 - of toolbar 5- 1
- drop-down menu 5- 1

[E]

- end
 - of application 4-11
 - of monitor 10- 3, 4
 - of test 10-21
- entering present value to address 11-28
 - check (QD75) 10- 2
- error
 - check (project) 8-16
 - code list 11-37
 - monitoring code 10- 4
 - monitoring the history of 10- 6

resetting of	7- 6, 8, 10- 1
existing	
opening project	6- 5
utilizing data	6- 9
[F]	
file reading of SW0D5C-AD75P-E	6- 9
file reading of SW1IVD-AD75P	6- 9
flash ROM	
initializing	9- 4
request	9- 4
function version	7- 5
[H]	
help	11-37
history monitor	10- 6
[I]	
I/O address	
checking of	7- 3
setting of	7- 2
icon	
arranging of	5- 1
reducing window to	5- 1
in execution	
block start data	10- 3, 4
positioning data	10- 3, 4
inching operation	10-31
information	
version of SW□D5C-QD75P-E	11-37
initialization (clear)	
of data	11-14
of QD75	9- 4
on column basis	11-13
on row basis	11-13
inserting circular interpolation into linear	
interpolation	8- 6
installation	4- 1
interface	7- 1, 2
[J]	
JOG operation	
monitoring	10-16
performing	7- 6, 10-30
jump	11-12

[K]	
keyboard operation	
block start data edit by	8-12
focus movement by	5- 4
for dialog box	5- 3
for project tree view	5- 2
parameter edit by	8- 1
positioning data edit by	8- 3
[L]	
license	2- 1, 3, 4- 1, 5, 7
list	
buffer memory address	11-37
error/warning code	11-37
function	3- 1
menu	3- 3
shortcut key	5- 4
tool button	5- 4
list box	5- 3
locus data	
simulation using	8- 9
trace using	11-35
[M]	
M code	
comment edit	8- 8
turning off the ON signal	11- 1
makeup	
of PLC	7- 4
of product	A-10
of system	2- 1
of this manual	1- 5
menu	
drop-down	5- 1
list	3- 3
right-click	5- 2, 8- 2, 10-20, 11- 8, 9
model selection	6- 2
module version	7- 5
monitor	
during OPR	10-15
of axis control status	10-11
of axis speed	10- 4, 13, 14
of axis status	10- 4
of block start data in execution	10- 3

of buffer memory	10-19
of external I/O signals.....	10- 9
of JOG operation	10-16
of MPG operation	10-16
of positioning data in execution.....	10- 3
of status signal.....	10-10
of X/Y device.....	10- 8
On/Off	10- 3, 4, 17, 19
QD75 error/warning history	10- 6
under position/velocity switching control	10-14
under velocity/position switching control	10-13
monitoring external I/O signals	7- 7, 10- 9
movement	
of cursor to specified data No	11-13
of focus	5- 4
MPG operation	7- 1
monitoring	10-16
performing.....	10-30
multiple PLC setting.....	7- 2
multiple	
opening projects	5- 2
writing to modules.....	11- 6
[N]	
navigation	11-17
new	
creating directory	6- 3
creating project	6- 2
QD75 read	6- 4
[O]	
On/Off	
monitor	10- 3, 4, 17, 19
of signal.....	7- 8, 10- 8, 9, 10
test.....	10-21
online	
positioning data edit during	11-29
status.....	4-11
Online toolbar	5- 1
open	
CSV file	6-12
project	6- 5
SW1IVD-AD75P-E file.....	6- 9
trace data file	11-32, 36
operation	
displaying results as locus data	11-35
displaying results as waveform data.....	11-31
JOG for specifying travel distance	10-30

monitor.....	10-11
monitoring status.....	10- 4
test	10-22, 25, 26, 28, 30
OPR	
monitor.....	8- 1, 9- 3
test	10-15
option.....	11-20
[P]	
parameter	
error (project).....	8-16
error (QD75)	10- 2
initialization	11-14
setting	8- 1
paste.....	11- 9
position/velocity control monitor	10-14
positioning data	
assisting the setting of	8- 6, 7
batch setting of	10- 2
comment.....	10- 5
comment display	11-10
copying of (axis basis)	11-15
cutting/copying/pasting of	11- 8
display color of	8- 5, 11-28
displayed number of.....	11-20
error (project) of.....	8-16
error (QD75) of.....	8-16
setting of	8- 3
preview	11-24
print.....	11-23
printer setting	11-22
procedure	
for opening project	6- 5
installation.....	4- 1
new QD75 read confirmation.....	6- 4
of navigation	11-17
of new project creation	6- 2
uninstallation	4- 6
work until positioning operation	1- 5
product	
information.....	11- 37
makeup.....	A-10
product ID.....	4- 3
project	
active	5- 2
makeup.....	6- 1
project path change	6- 3

project tree view	5- 1
[Q]	
Q corresponding MELSECNET/H network remote I/O module	1- 1, 2- 2, 7- 1, 9- 1
Q corresponding serial communication module... ..	1- 1, 2- 1, 7- 2, 3
QD75	
initialization	10- 4
model selection.....	6- 2, 11- 3
read from.....	10- 1
verify.....	10- 1
write to.....	10- 1
QD75 ready signal (X0)	11-21
[R]	
radio button.....	5- 3
read	
from HD/FD.....	6- 5
from QD75	10- 1
from SW0D5C-AD75P-E format file.....	6-10
from SW1IVD-AD75P-E format file.....	6-10
of trace data	11-32, 36
remote I/O	7- 1
right-click menu	5- 2, 8- 2, 10-20, 11- 8, 9
row clear	11-13
RS-232C cable	2- 1, 7- 1
[S]	
sampling monitor	10-17
save	6- 6
save	
data in flash ROM of QD75	9- 4
of automatic refresh setting.....	11- 6
of project	6- 6
of trace data	11-32, 36
save as	6- 6
Select all	11-11
setting	
assisting	8- 6, 7, 11-17
of block start data	8-12
of condition data	9-10
of M code comment.....	8- 8
of parameters.....	8- 4, 5
of parameters.....	8- 1
of positioning data	8- 3
of print range.....	11-23

of printer	11-22
of selection range in batch.....	11-10
option	11-20
shortcut key.....	5- 4
signal monitor.....	10- 8
single-module test.....	10-21
software registration card	4- 3
specifying access target	7- 1
speed	
automatic setting of	8- 7
monitoring.....	10- 4, 13, 14
speed change test.....	10-26
spin box	5- 3
spreadsheet software data	
copying from.....	11- 9
reading.....	6-12
writing to	6-13
start	
of application	4-10
of monitor.....	10- 3, 4, 17, 19
of test	10-21
status bar.....	5- 1
status signal monitor.....	10-10
stop	10- 1
switching	
of block to be edited	5- 1, 8-12
of window.....	5- 4
system configuration.....	2- 1
system monitor.....	7- 4
[T]	
tab.....	5- 3
teaching.....	11-28
test	
by JOG operation	10-30
by MPG operation	10-30
of block start data	10-22
of ON/OFF of external I/O signals	7- 6
of positioning data	10-22
of QD75 alone	10-21
On/Off	10-21
OPR	10-28
present value change.....	10-25
speed change.....	10-26
test mode	
positioning data edit in	11-28
shift to	10-21

test without external device..... 10-21
text box 5- 3
time-out..... 7- 2
title bar 5- 1
toolbar 5- 1
trace
 displaying the results of..... 11-33, 35
 setting the conditions of..... 11-29, 33
trace data file
 read of 11-32, 34
 write of..... 11-32, 34

[U]

uninstallation..... 4- 6
USB.....2- 1, 2, 7- 2
utilizing AD75 data 6-10

[V]

velocity/position control monitor..... 10-13
verify
 verifyof project 11- 1
 verifywith QD75 10- 1
version
 of QD75..... 7- 5
 of SW□D5C-QD75P-E 11-37
virtual positioning..... 8- 9

[W]

warning
 checking code definition 11-37
 monitoring the history of 10- 6
waveform data
 sampling using..... 10- 17, 19
 simulation using 8- 9
 trace using 11-29, 31
window
 cascade..... 5- 1
 close all 5- 1
 tile..... 5- 1
Windows® 2- 1, 2, 4
wiring-free test..... 10-21
write
 batch
 in CSV format 6-13
 of trace data 11-32, 36
 to flash ROM..... 10- 4
 to HD/FD 6- 6
 to QD75..... 10- 1

[X]

X device monitor 10- 8

[Y]

Y device monitor 10- 8

Microsoft, Windows and Microsoft Windows NT are registered trademarks of Microsoft Corporation in the United States and other countries.

Pentium is either a trademark or registered trademark of Intel Corporation in the United States and other countries.

Other company and product names herein may be either trademarks or registered trademarks of their respective owners.

Positioning Module Software Package

Operating Manual

MODEL	SW0D5C-QD75P-O-E
MODEL CODE	13J973
SH(NA)-080057-C(0010)MEE	



HEAD OFFICE : MITSUBISHI DENKI BLDG MARUNOUCHI TOKYO 100-8310 TELEX : J24532 CABLE MELCO TOKYO
NAGOYA WORKS : 1-14 , YADA-MINAMI 5 , HIGASHI-KU, NAGOYA , JAPAN

When exported from Japan, this manual does not require application to the Ministry of International Trade and Industry for service transaction permission.

Specifications subject to change without notice.